



ARKEL



ADrive

VVVF Motor Sürücü

VVVF Drive

KULLANICI KILAVUZU

USER MANUAL

TR/EN

Publisher ARKEL Elektrik Elektronik Ticaret Ltd. Şti.
Şerifali Mah. Bayraktar Bulvarı Şehit Sk.
No:32 Umraniye İstanbul TURKIYE
TEL: (+90 216) 540 67 24
Fax: (+90 216) 540 03 09
E-mail : info@arkel.com.tr
www.arkel.com.tr

Date of issue 2012

Document version V4.0

Hardware version V2.7C

Software version V8.82

This document has been created to be a guide for Arkel customers. Reproduction, transfer, distribution or storage of part or all of the contents in this document in any form without the prior written permission of Arkel is prohibited. Arkel reserves the right to make changes and improvements to any of the products described in this document without prior notice.

Arkel is not responsible for those mistakes that may be found in this manual and for the damages that they may cause.

CONTENT

CONTENT	81
1.INTRODUCTION.....	84
2.EMC CONFORMITY	85
3.WARNINGS	86
4.DELIVERY CONTENTS.....	87
5.TECHNICAL SPECIFICATIONS.....	88
6. FUSE, CONTACTOR and CABLE CROSS-SECTION	89
7. Dimensions and Mounting of ADrive	90
8. ADrive Line Filter (EMI)	93
9. ADrive Braking Resistors.....	94
10. RFI FILTER (Zero-phase Reactor).....	96
11. AC line reactor (Line choke)	97
12. ENCABIT-Plus Module.....	98
13. ADrive Connections	99
13.1. POWER TERMINAL CONNECTIONS	100
13.1.1. Mains power connection:	100
13.1.2. Brake resistor connection:.....	100
13.1.3. Motor connection:	101
13.2. CONTROL TERMINAL CONNECTIONS	103
13.2.1. Drive command inputs:.....	103
13.2.2. Control input-output signals:	105
13.2.3. Incremental encoder connection for asynchronous motors.....	108
13.2.4. Absolute encoder connection for synchronous motors	111
13.2.5. Mechanical brake release monitoring	115
13.2.6. Motor & brake resistor temperature monitoring.....	115
13.2.7. Manual evacuation mode activation input.....	116
13.2.8. External 24V power supply.....	117
13.2.9. The connection between ENCABIT-Plus module and ADrive	117
13.2.10. Inputs/Outputs on ENCABIT-Plus module	118
13.2.11. Serial communication with ARL-500 Lift Controller.....	119
13.2.12. ADrive Remote Keypad Connection	119
13.3. EMERGENCY EVACUATION OPERATION.....	120
13.3.1. General information:	120
13.3.2. Required back-up power supplies:	120
13.3.3. Evacuation in the lower load direction:	121
13.3.4. Evacuation Towards Command Direction:	122
13.3.5. Back-up power wirings for evacuation operation:	124
13.3.6. Process of an evacuation travel:	126
14. PC CONNECTION.....	127
14.1. ADrive-Win Simulator & Monitor Software.....	127
14.2. Firmware Upgrading	127
15. Data Key	128
16. LCD SCREEN AND KEYPAD USAGE	129
1.1. STARTUP SCREEN	130
16.2. MONITORING SCREENS	130
17. ADrive Parameters.....	132
1-TRAVEL CURVE	133
2-MOTOR SETUP.....	136
3-CONTROLLER SETUP.....	141
4-KEY READ/WRITE.....	143
5-FAULT HISTORY	143

6-CONTROL TYPE.....	143
7-LANGUAGE	143
8-FACTORY DEFAULT	143
9-AUTO TUNE.....	144
10-PASSWORD.....	144
11-ADVANCED SET	145
12-BATTERY OPERATION.....	148
18. HOW TO ADJUST FOR OPEN LOOP PRACTICALLY	149
19. HOW TO ADJUST FOR CLOSED LOOP PRACTICALLY	150
20. DRIVING SYNCHRONOUS MACHINES with ADrive	151
21. TRIPS.....	154
22. NOTES	159
23. ADrive PARAMETER LIST.....	160

PREFACE

This documentation describes the inverter model ADrive

It contains important information about:

- equipment configuration
- connection
- control system
- operating
- starting
- service

Disclaimer:

The containing information specifies the properties of the products without ensuring them. The right for technical changes is reserved.

Copyright

Copyright by **Arkel** Elektrik Elektronik Tic. Ltd. Sti.

It is not allowed to redistribute the manual in its entirety or parts of it. Violations will be prosecuted and lead to indemnity.

1. INTRODUCTION

ADrive is a high performance motor driver designed for elevators.

Can be used with asynchronous (open loop/closed loop) and synchronous lift motors.

Provides an evacuation operation by driving the motor with back-up power (60-120V battery or 1-phase 220V UPS).

Provides a static auto-tuning for synchronous motors (without rotating the motor).

It supports many different types of absolute (EnDat, SSI and SinCos) and incremental (HTL, TTL) encoder.

The functions of ADrive are improved to get the best performance especially at startup and stop. Startup and stop accuracy does not change with full load or empty car (for applications with encoder).

Thanks to vector control, it has the full control of motor from zero speed to maximum speed and can achieve 200% start-up torque.

For short travel distances the travel curve is automatically readjusted and boring travels at low speed for short levels are impeded.

The parameter units are convenient for elevators (m, cm, m/s etc.).

The mechanical fan noise and electrical switching noise are minimized, by this no disturbing noises for residences close to machine rooms are produced.

2. EMC CONFORMITY

This product is in conformity with:

- EN 61000-6-2 Generic standards immunity for industrial environments,
- EN 61000-6-4 Generic standards emission for industrial environments,
- EN 55011 Limits and methods of measurement of radio disturbance characteristics of industrial, scientific and medical (ISM) radio-frequency equipment and
- EN 61000-3-12 Limits for harmonic currents produced by equipment connected to public low-voltage systems with input current 16 A and 75 A per phase

with the following installation conditions:

- Installing an AC line reactor to the drive power supply input.
- Installing an EMI filter to the drive power supply input.
- Installing a RFI filter to the drive motor output.
- Using shielded cables for motor, brake resistor and encoder connections outside the device.

3. WARNINGS



After switching off the device do not touch any electronic board or components until the power capacitors are discharged (Min.5 minutes).



Do not make any connection to inverter when the power is on. Do not check components and the signs on the electronic boards while device is running.



Be sure that the mains connections are correct. L1, L2 and L3 are line input terminals and must not be disordered U, V and W. Otherwise, device may be damaged.



Do not mount the brake resistor on controller cabinet. Brake resistor must be mounted vertically outside the control cabinet.



Do not place device near flammable objects in order to prevent fire.



To prevent overheat, damage and fire be sure that the environment has sufficient ventilation.



Do not store and operate the device at environments with extreme heat, extreme cold, extreme humidity, water, iron dust and dust.



It is necessary that the used motor has a winding isolation which is made for the operation with VVVF inverter.

4. DELIVERY CONTENTS

- User manual (This product)
- Documentation and software CD
- PC RS-232 connection cable
- Data Key for transferring parameters
- RFI Filter (Zero-phase reactor)
- Braking resistor (Optional)
- EMI line filter (Optional)
- AC line reactor (Optional)
- ENCABIT-Plus encoder interface module (Required for synchronous drive)
- ADrive Remote Keypad for remote operation of ADrive (Optional)

5. TECHNICAL SPECIFICATIONS

Type	Size-B			Size-C		Size-D
Model	4B055	4B075	4B110	4C150	4C220	4D370
Motor Power (HP)	5.5 kW 7.5HP	7.5 kW 10HP	11 kW 15HP	15 kW 20HP	22 kW 30HP	37 kW 50HP
Nominal Output Current (Inom)	14 A	17 A	26 A	35 A	50 A	75 A
Maximum Output Current (< 6 s)	28 A	34 A	52 A	70 A	100 A	140 A
Input Power Factor (Cos Q)	> 0.97					
Input Voltage (V)	AC 3 Faz, 340-420V, 50/60 Hz ±%5					
Output Voltage (V)	AC 3 Faz, 0-400V, 0-100Hz					

Control Type	<ul style="list-style-type: none"> • Closed Loop Vector Control • Open Loop V/F (for asynchronous drive) 	
Digital output frequency resolution	0,004 Hz	
PWM modulation method	Space vector modulation	
Output wave shape	Sinus	
Carrier frequency	10Khz	
Encoder type	Incremental	HTL or TTL , 500 – 4096 pulse incremental encoder
	Absolute	EnDat, SSI and SinCos absolute encoders
Encoder simulation outputs	<ul style="list-style-type: none"> • Absolute encoder simulation outputs • Incremental encoder simulation outputs 	
Protection	Built-in DC REACTOR (Dc choke)	
Input-output isolation	All isolated control inputs and outputs	
Cooling	4 low noise fans	
Serial communication ports	<ul style="list-style-type: none"> • RS-485 port for communication with lift controller • CANbus port for communication with ENCABIT-Plus 	
Evacuation operation with back-up power	Control circuit supply	With external 24Vdc feeding
	Power circuit supply	<ul style="list-style-type: none"> • 60-120VDC battery • 1-phase 230VAC UPS
Special functions for synchronous drive	<ul style="list-style-type: none"> • Motor and brake resistor temperature monitoring • Brake release monitoring • Manual evacuation mode activating input & special evacuation screen 	
Fault history	Last 256 errors	
Onboard user interface	2x16 character LC-Display & 5-key keypad	
Remote operation	With ADrive Remote Keypad	
PC connection	RS-232 port (for ADrive-Win Simulator & Monitor software)	
Saving and transferring parameters	With Data Key	
User interface	2x16 character LC-Display, 5-key keypad	
Firmware upgrading	Firmware version V8.00 and later	

6. FUSE, CONTACTOR and CABLE CROSS-SECTION

Fuses (Ampere)	7.5HP 5.5kW	10HP 7.5kW	15HP 11kW	20HP 15kW	30HP 22kW	50HP 37kW
Mains fuse (Type B)	20	25	32	50	63	100
Battery fuse (Type C)	1.5 x battery capacity (Ah)					
UPS fuse (Type B)	1.5 x (UPS power (W) / 220V)					

Contactors (Ampere, category AC-3)	7.5HP 5.5kW	10HP 7.5kW	15HP 11kW	20HP 15kW	30HP 22kW	50HP 37kW
Motor contactors (KPA, KPB)	>= 12	>=18	>=25	>=32	>=50	>= 80
Mains supply contactor (KSAK)	>= 9	>=12	>=18	>=25	>=40	>= 65
Back-up power supply contactor (KKAK)	>= 9	>=9	>=12	>=18	>=32	>= 50

Cable cross-section (mm ²)	7.5HP 5.5kW	10HP 7.5kW	15HP 11kW	20HP 15kW	30HP 22kW	50HP 37kW
Mains supply cables	>= 2.5	>= 4		>= 6	>= 10	>= 16
Motor connection cables	>= 2.5	>= 4		>= 6	>= 10	>= 16
Brake resistor cables	>= 1	>= 1.5		>= 2.5		>= 4
Battery power connections	>= 1.5	>= 2.5		>= 4	>= 6	>= 10
UPS power connections	*1	>= 1	>= 1.5	>= 2.5	>= 4	>= 6
	*2	>= 1.5	>= 2.5	>= 4	>= 6	>= 10
Control signal cables	>= 0.5					

*1: Evacuation in the lower load direction

*2: Evacuation in the command direction given by the lift controller

7. Dimensions and Mounting of ADrive

ADrive inverter must be installed in a vertical position and must be fitted with its terminal strips and connecting bars to the bottom. Make sure that the cooling air intake and discharge are not restricted in any way. To ensure this allow a gap of at least 10 cm above and underneath the unit. Mount using the mounting holes and using at most 12 mm M6 nuts.

7.1. Physical Dimensions of ADrive Size-B and Size-C

ADrive Size-B (7.5HP / 10HP / 15HP)

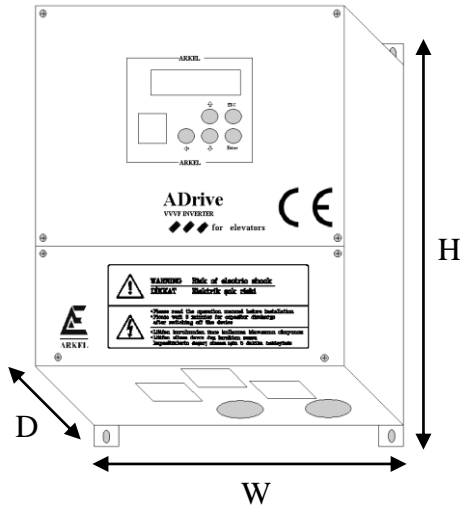

ADrive Size-C (20HP / 30HP)

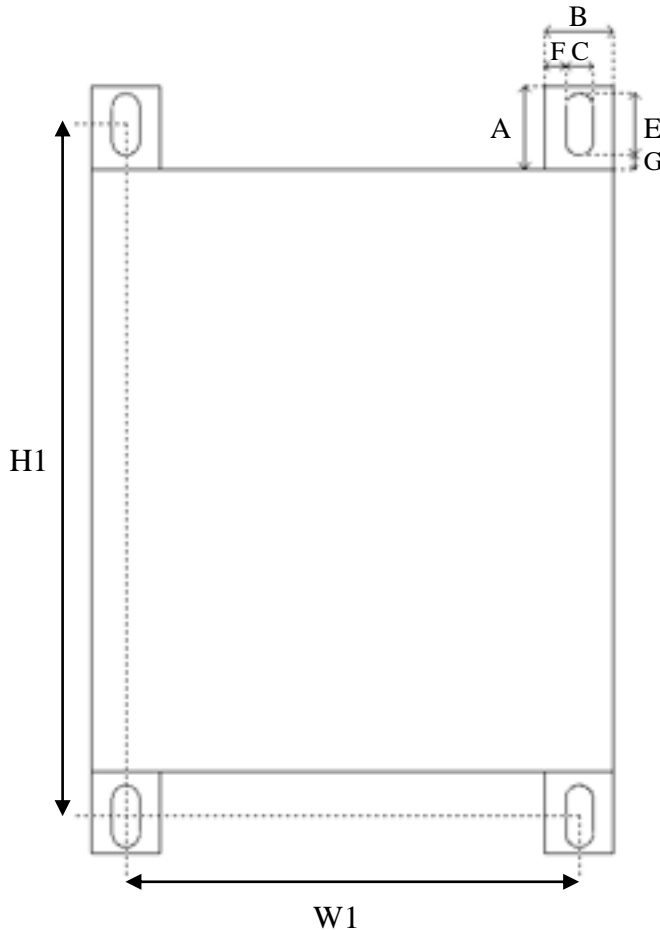
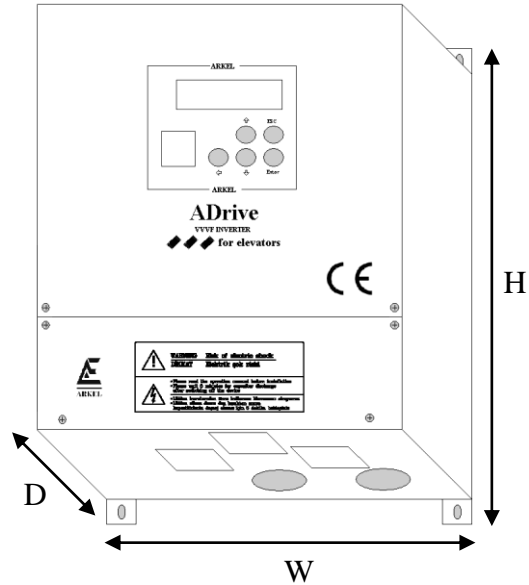

Dimensions (mm)	ADrive Size-B	ADrive Size-C
W	260	289
H	387	442
D	184	205
H1	360	420
W1	230 ± 5	250 ± 5
A	30	
B	24	
C	8	
E	18	
F	8	
G	8	

7.2. Physical Dimensions of ADrive Size-D

ADrive Size-D (50HP)

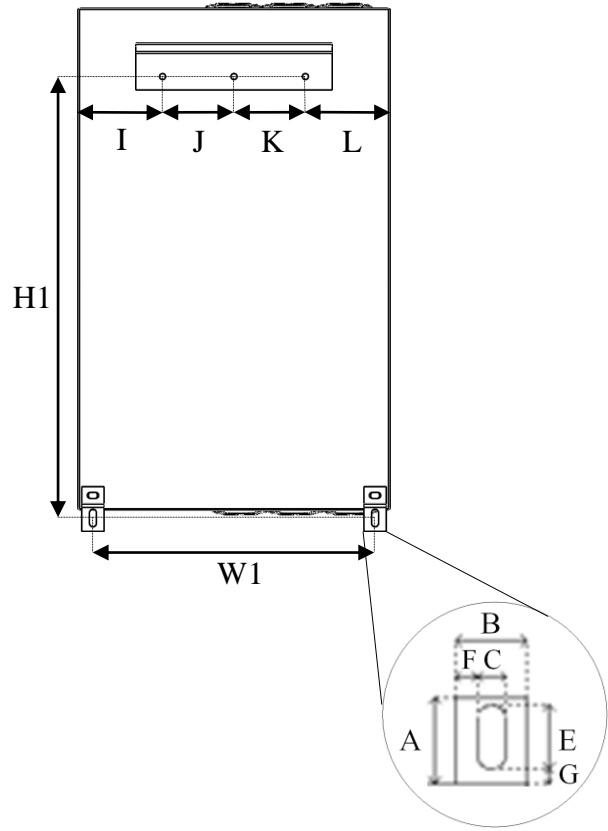
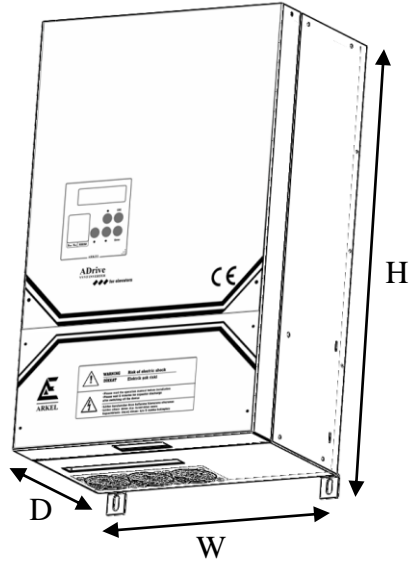

Dimensions (mm)	ADrive Size-D
W	350
H	590
D	236,5
H1	495
W1	316
A	30
B	24
C	8
E	18
F	8
G	8
I	95
J	80
K	80
L	95

7.2.1 Mounting of ADrive Size-D

Unlike ADrive Size-B and Size-C, ADrive Size-D has 2 mounting brackets while mounting.

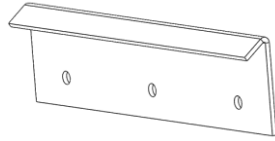

Size-D mounting device

For mounting the device ADrive Size-D, follow the steps below:

Step 1: Screw one of the mounting devices and fastening brackets as shown in the figure.

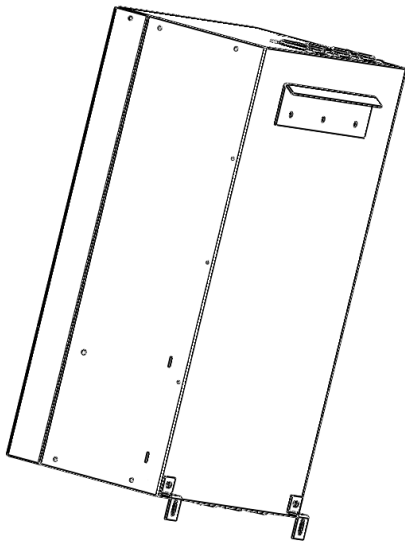

Step 2: Screw the other mounting device to control panel as shown.

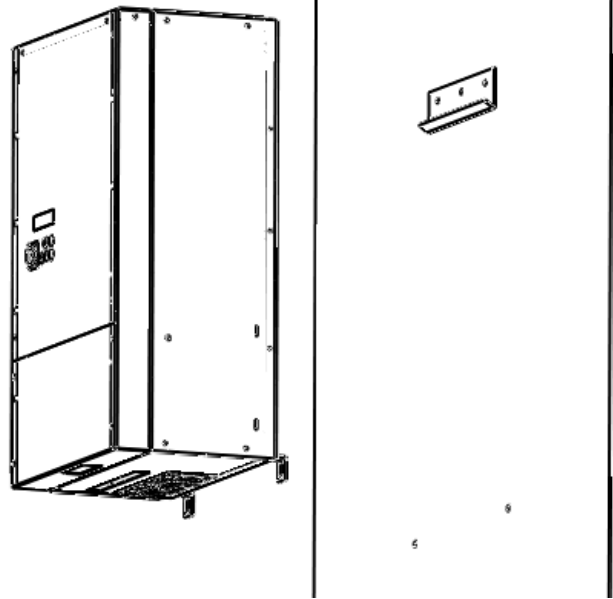

Step 3: Hang ADrive Size-D to the mounting device on the control panel.

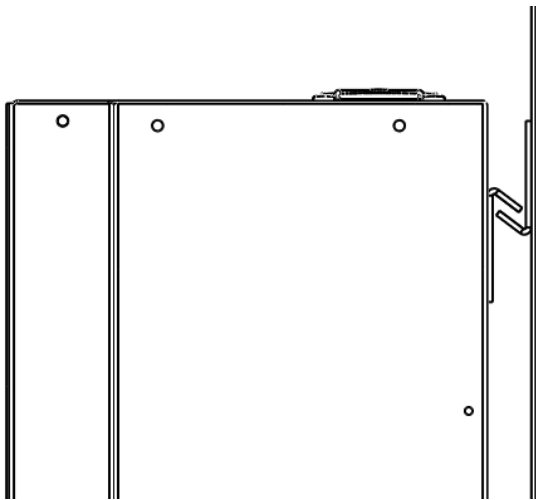

Step 4: Mount the device to control panel from two fastening brackets at the bottom of ADrive Size-D.



8. ADrive Line Filter (EMI)

Two types of EMI filter are used for ADrive Inverter models.

ADrive		Recommended EMI Filter	Description
Size-B	7.5 HP	EMC-30	3x400VAC, 50-60HZ, 30A
	10 HP		
	15 HP		
Size-C	20 HP	EMC-50	3x400VAC, 50-60HZ, 50A
	30 HP		
Size-D	50 HP	-	3x400VAC, 50-60HZ, 80A

EMI Filter can be installed in a vertical or horizontal position. But it is recommended to install the filter as load side comes close to ADrive input terminals.

8.1. Dimensions of ADrive Line Filter

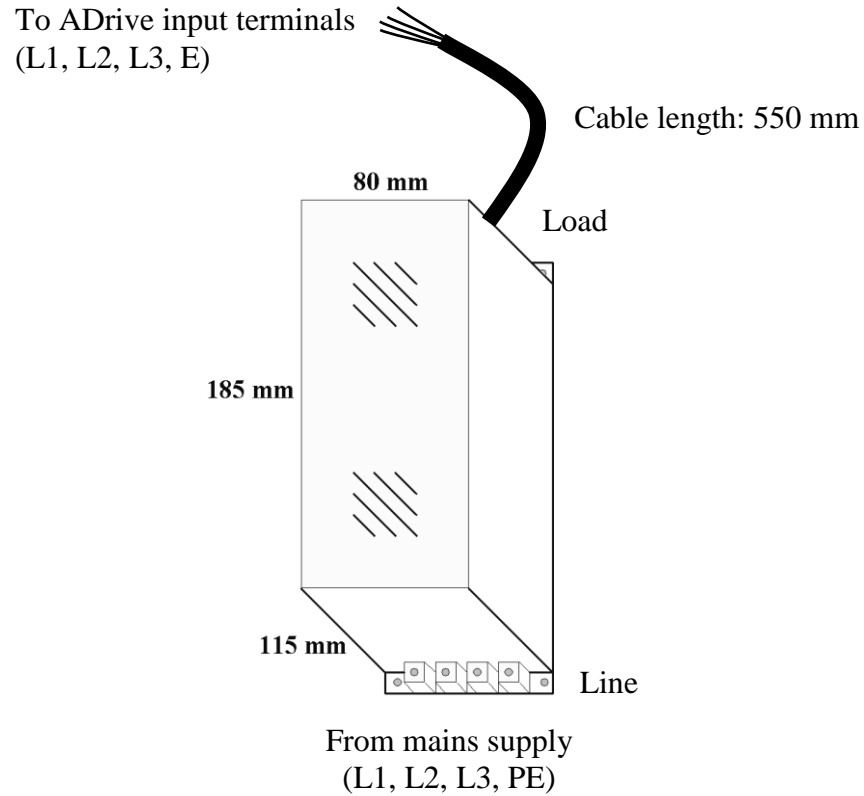

9. ADrive Braking Resistors

Recommended braking resistors for ADrive models are shown below:

ADrive		Recommended Braking Resistor Resistance (Ω) / Power (kW)		
kW	HP	Type-A	Type-B	Type-C
5.5	7.5	50 Ω / 1kW		
7.5	10	50 Ω / 1kW		
11	15	40 Ω / 1kW		
15	20		25 Ω / 2kW	
22	30		18 Ω / 3kW	
37	50			10 Ω / 6kW



Dangerous high voltage on the brake resistor connections and on the braking resistor itself.



Braking resistor must be installed in a **horizontal** position for best heat dissipation and must be fitted with its connecting bars.



Do not mount the braking resistor on the controller cabinet. While mounting, be aware that excessive heat dissipated by the brake resistor may damage the control panel, cause malfunctions or start a fire. The temperature of the break resistor housing can attain 100°C during operation.



The brake resistor must be mounted in a dry location and must be fixed properly against vibrations.



There must be minimum 30 cm of gap above and below the brake resistor to provide air ventilation.



The capacity of brake resistors may increase due to the operating frequency of elevator and maximum journey duration.

9.1. Dimensions of Braking Resistors

9.1.1. Braking Resistor Type-A (7.5 HP, 10 HP, 15 HP)

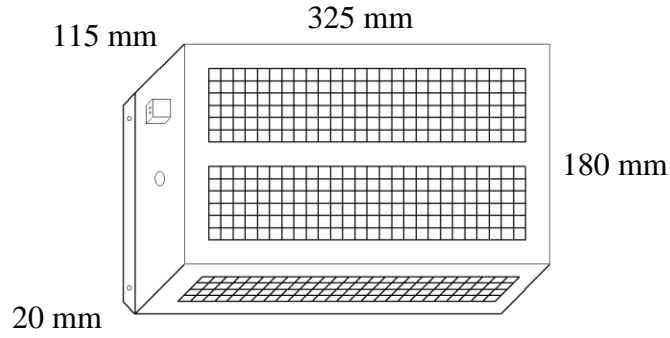

9.1.2. Braking Resistor Type-B (20 HP, 30 HP)

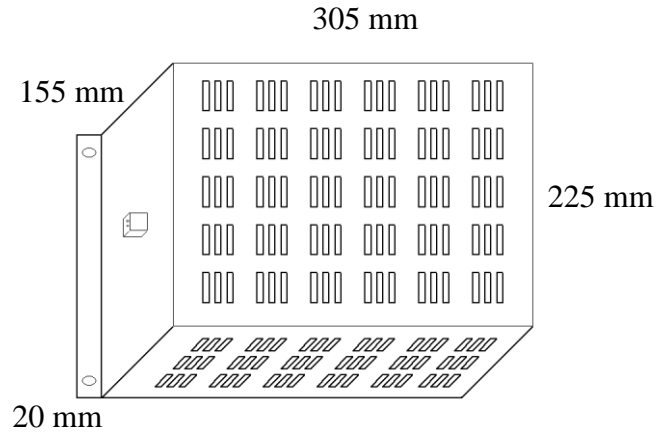

9.1.3. Braking Resistor Type-C (50 HP)

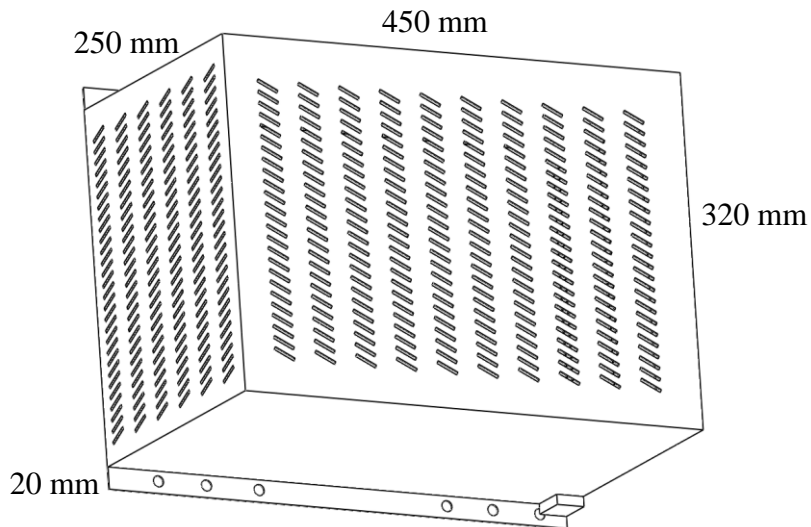

10. RFI FILTER (Zero-phase Reactor)

The RFI Filter helps reduce radiated noise from the motor wiring. It is used on the output side of the inverter. The example RFI Filter is shown below.

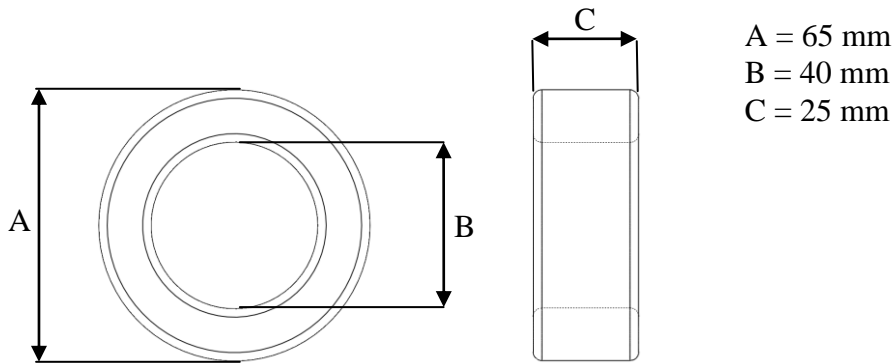

Toroidal transformer core

10.1. The wiring of ADrive Size-B and Size-C to RFI Filter

The toroidal transformer core comes with the inverter is used for RFI filter. The wiring must go through the opening (U, V, W) to reduce the RF component of the electrical noise. Loop the wires two times to attain the full RFI filtering effect. Install the toroidal core near the inverter as close as possible.

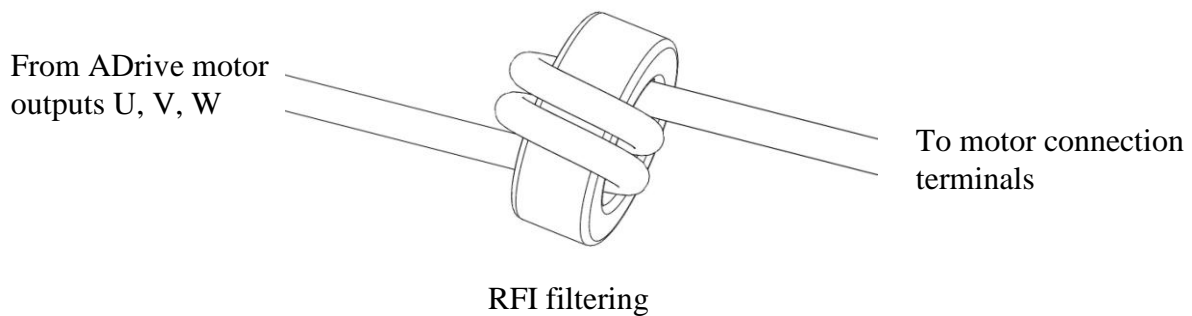

10.2. The wiring of ADrive Size-D RFI Filter

The toroidal transformer core comes with the inverter is used for RFI filter. The wiring must go through the opening (U, V, W) to reduce the RF component of the electrical noise. Loop the wire one time to two toroid to attain the full RFI filtering effect. Install the toroidal cores near the inverter as close as possible.

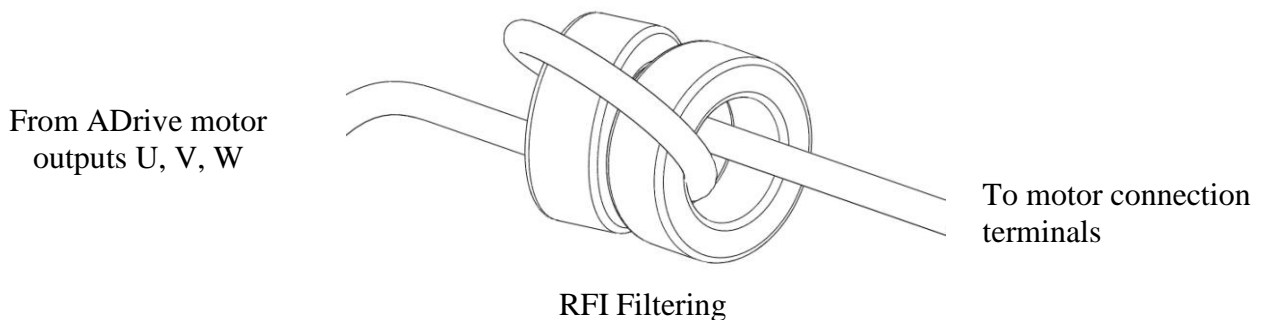

11. AC line reactor (Line choke)

A 3-phase AC line reactor must be used to comply with the harmonic current limits required by the EN 61000-3-12 standard.

Note: A DC reactor is integrated inside all ADrive models.

Selection of AC line reactor (380V, 50Hz)					
ADrive size		Continuous current (A)	Max. peak current (A)	Inductance (mH)	
kW	HP			%3 impedance	%5 impedance
5.5	7.5	>= 14	>= 28	1.6	2.7
7.5	10	>= 17	>= 34	1.3	2.2
11	15	>= 26	>= 52	0.9	1.5
15	20	>= 35	>= 70	0.7	1.2
22	30	>= 50	>= 100	0.5	0.9
37	50	>= 75	>= 140	0.3	0.5

Note: It is recommended to use AC line reactors with impedance values 3% (Z%) for standard applications. The impedance value %Z is also the voltage value that drops across the AC line reactor (for example: 5% voltage drops across the AC line reactor with impedance value 5%). 5% reactor would be a better choice for reducing the harmonic currents with a balanced mains supply (less than 5% voltage imbalance between phases).

It is suggested that a 3-phase AC line reactor be installed on the supply line also to obtain the following benefits:

- limiting the input current peaks on the input circuit of the inverter
- increasing the duration of line capacitors inside the inverter
- increasing power factor, thus reducing line current

12. ENCABIT-Plus Module

12.1. Description

An external ENCABIT-Plus module is mounted to the device for synchronous applications. The absolute encoder connection and other functions used for synchronous motors are provided with the support of ENCABIT-Plus module.

12.2. Mounting

ENCABIT-Plus module is installed to the bottom right of ADrive as ENCABIT-Plus mounting ears comes to the appropriate slots on ADrive.

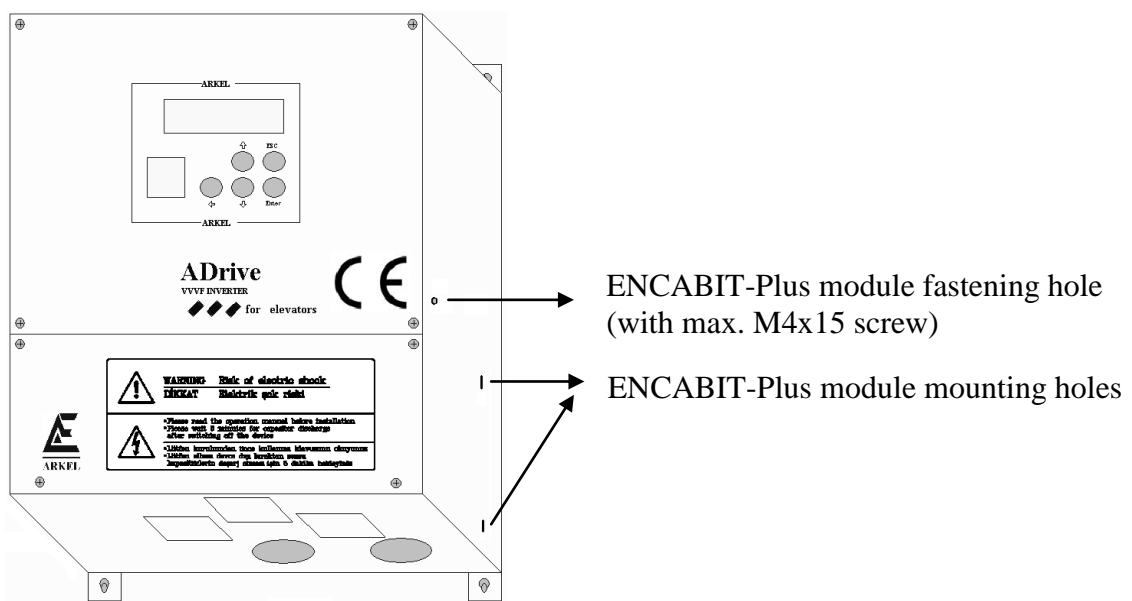
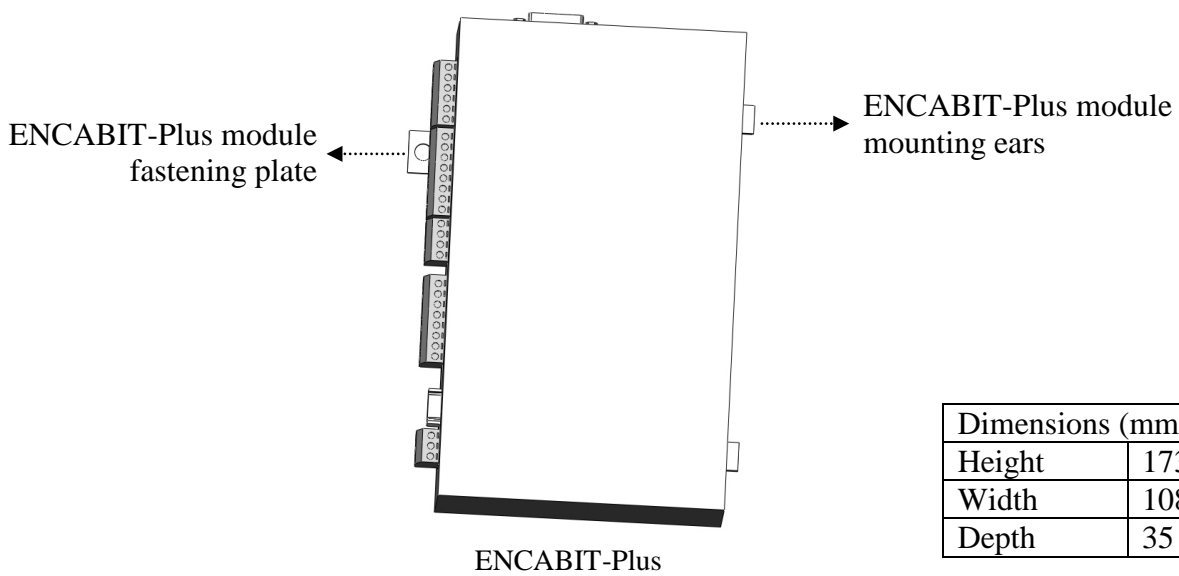

Assembly of ENCABIT-Plus module to ADrive

13. ADrive Connections

13.1. Connections of ADrive Size-B and Size-C

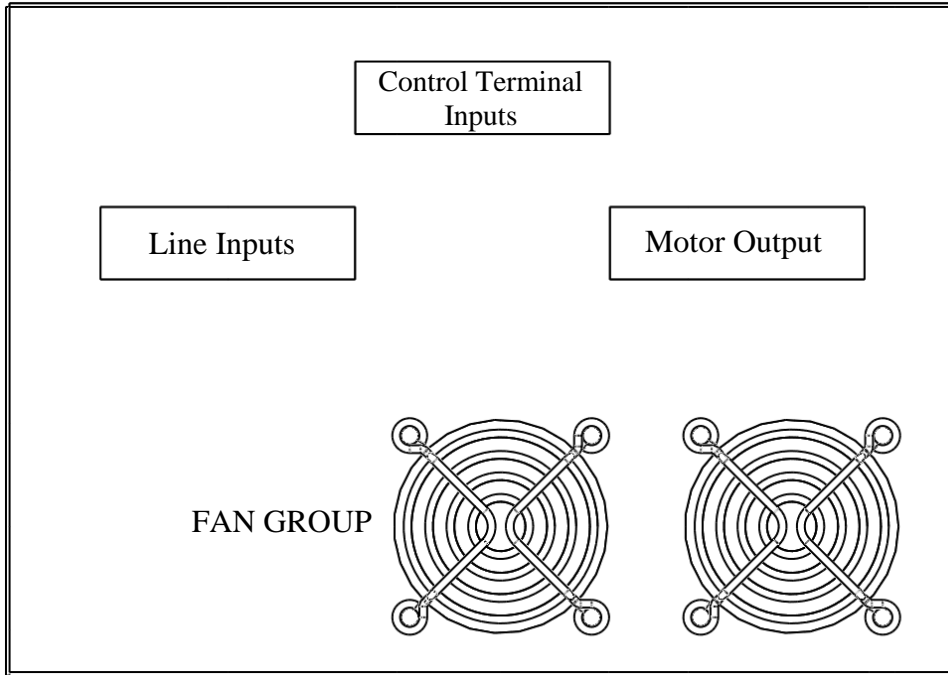

Bottom view of ADrive Inverter

13.2. Connections of ADrive Size-D

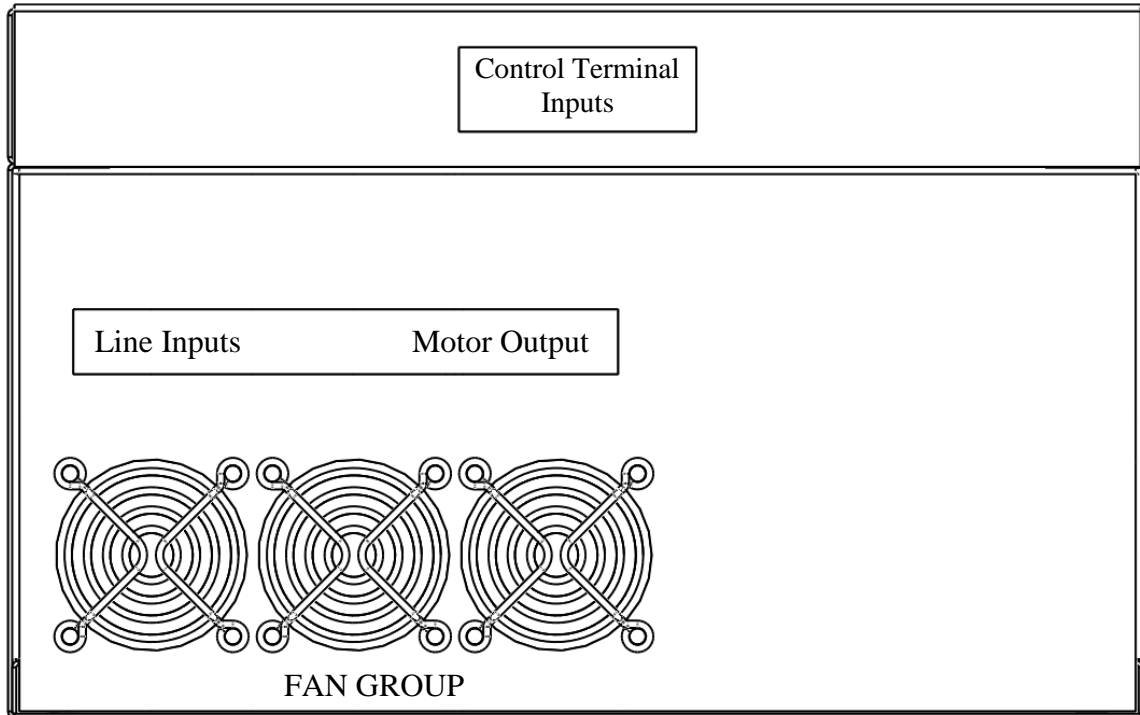

Bottom view of ADrive Inverter

13.3. POWER TERMINAL CONNECTIONS

Symbol	Description
L1(R)	Mains inputs
L2(S)	
L3(T)	
E	Earthing terminal.
B	Braking resistor transistor output (-)
P	DC Bus positive voltage, Braking resistor transistor output (+)
N	DC Bus negative voltage (This terminal is located in only ADrive Size-B and Size-C)
U	Motor outputs
V	
W	

13.3.1. Mains power connection:

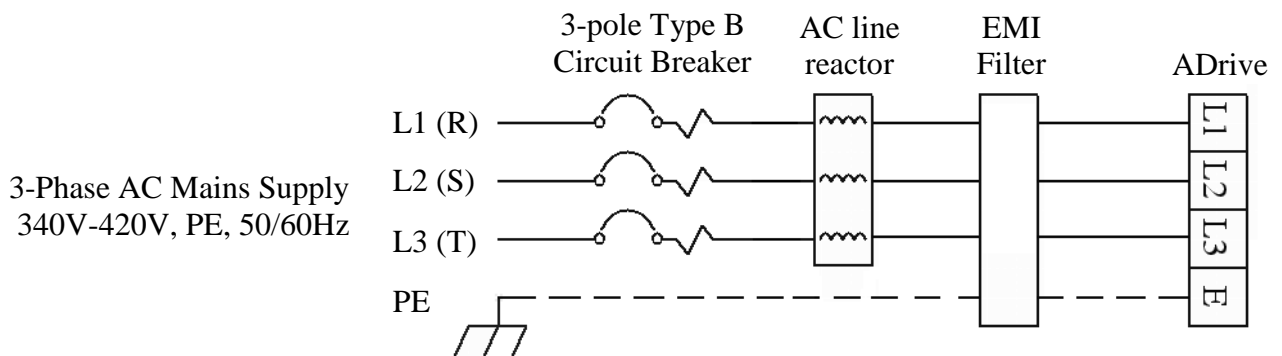

Use a cable with an appropriate cross-section (For more information see Chapter 6)

13.3.2. Brake resistor connection:

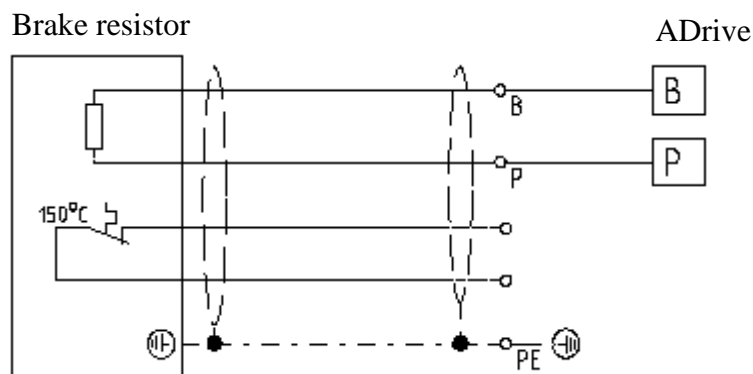

Use a shielded cable with an appropriate cross-section (For more information see Chapter 6)

13.3.3. Motor connection:

13.3.3.1. Asynchronous motor connection:

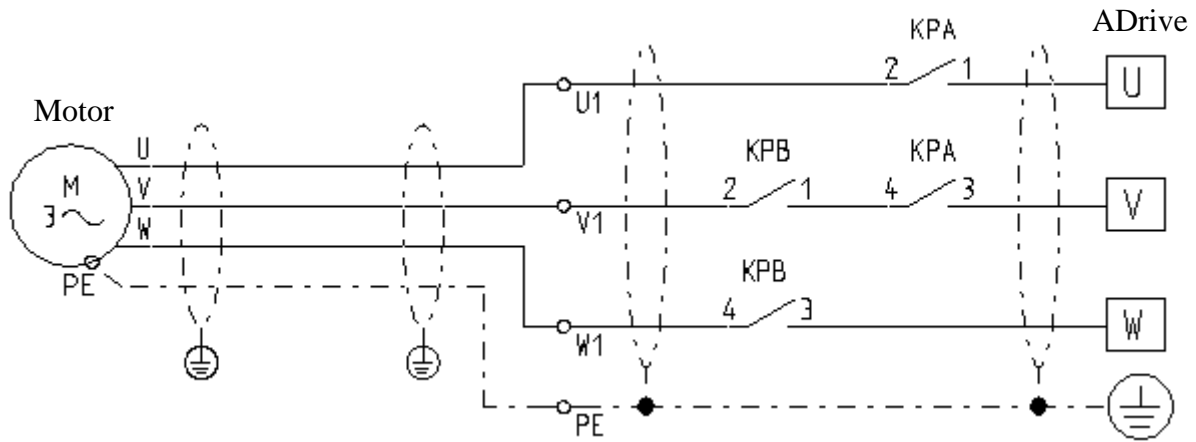

13.3.3.2. Synchronous motor connection:

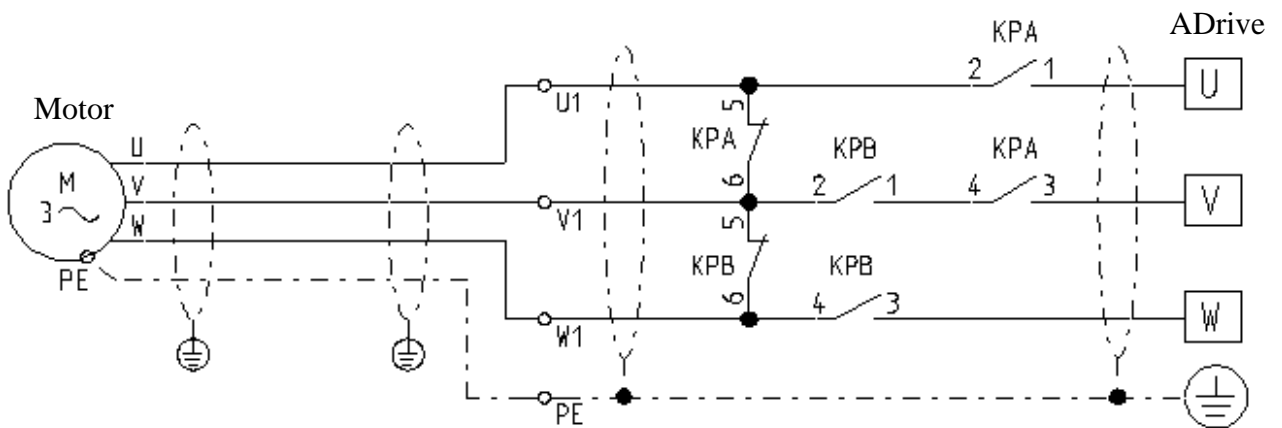

13.3.3.3. Consider the following statements for motor connection:



2 serial contactors must be used at motor circuit for conformity to EN-81.



The drive enable signal (EN) must be switched by the open contacts of KPA and KPB. Otherwise the inverter will continue driving the motor after the contactors are off. Meanwhile If the contactors are on again the outputs of the inverter may be damaged because of over current.



For synchronous drive, 2 main contactors with 4 main contacts each has 2x NO and 2x NC main contacts are required for motor connection. The motor windings must be short circuited with NC main contact of each main contactor to prevent an uncontrolled acceleration of the synchronous motor (See wiring diagram). Due to the high current, main contacts **MUST** be used for short circuiting.



For synchronous drive, the drive enable signal (EN) must also be switched by a NO contact of an auxiliary relay. The auxiliary relay has to be connected parallel to the travel contactors. (See chapter 13.2.1.1)



The length of the motor wire should not be longer than 10 meters. If the motor wire need to be longer than 10 meters, a motor output reactor is recommended.



Use a shielded cable with an appropriate cross-section (For more information see Chapter 6)



Motor cable must both be grounded both the inverter and the motor.



Motor cable must be pulled away from the other cables as far as possible.



The placement of the motor cables must not be parallel to other cables. If necessary, the angle between the motor cable and other cables must be 90 degree.



Cables must have at least +60 °C temperature resistance.



For a suitable ground connection, the shield of motor cable should be fixed to ground plate with metal clamps.

13.2. CONTROL TERMINAL CONNECTIONS

13.2.1. Drive command inputs:

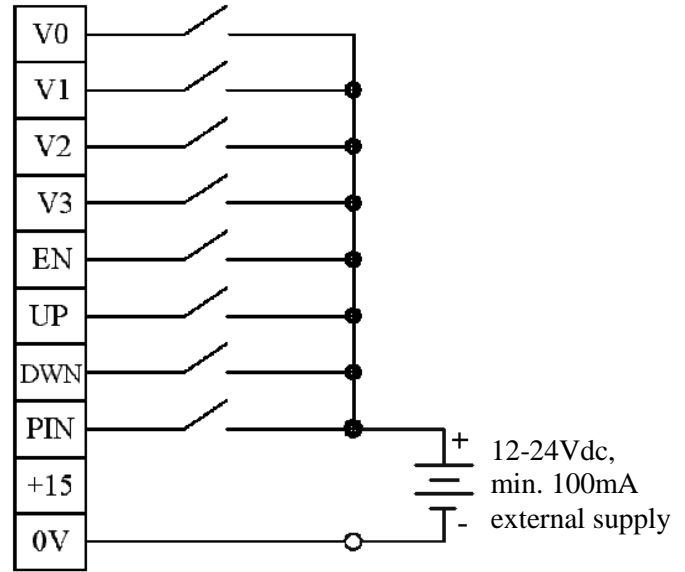
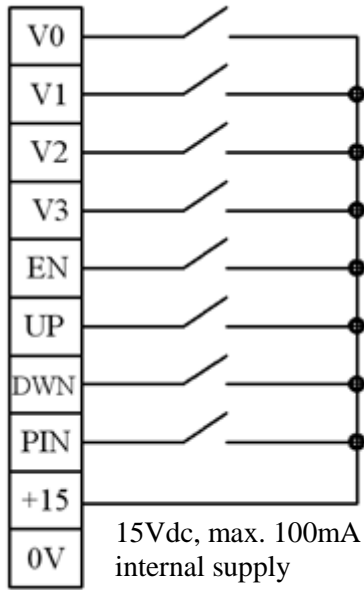

a) Connection with internal power supply

b) Connection with external power

Digital input specifications:	
Max. voltage	26Vdc
Clamping range	Maks. 2,5 mm ²

Drive command input terminals:		
V0	Speed-0	Low speed
V1	Speed-1	Inspection speed
V2	Speed 2	Intermediate speed
V3	Speed-3	High speed
EN	ENABLE	Drive enable (Must be switched by the open contacts of KPA and KPB main contactors)
UP	UP	Travel direction up
DWN	DOWN	Travel direction down
PIN	Programmable input	Programmable digital input. Can be assigned as "Error Reset" or "Shaft Limit Cnt." in the menu.
+15	+15V reference voltage	Reference voltage for digital inputs (Imax: 100 mA)

- In a case of more than one speed inputs applied the higher one is activated.
- If the speed control inputs are driven by relay contacts, high speed and low speed signal should be applied together. Otherwise, because of the relay contact delay, wrong speed inputs may be perceived at speed changes especially for distance controlled stops it is important that there must be no delays at speed transitions.

13.2.1.1. Recommended connection of enable signal (EN) for synchronous drive

ADrive motor driver checks the activation-releasing of the main contactors (KPA, KPB) with ENABLE input. The main contactors must be activated before the inverter starts driving. Similarly, before the main contactors are released, device must stop driving. However, when the safety circuit is interrupted during motor drive, due to the releasing of the main contactors will take a certain time, the ENABLE signal interruption will be delayed and the motor circuit will be opened by the main contactors while the device is still continue to driving. This situation may cause excessive current draw from the device. Driver will give IPM error in these cases.

Therefore, to avoid this situation that shorten the life-time of the device, it is recommended to switch the drive enable signal (EN) also from a NO contact of an auxiliary relay. The auxiliary relay has to be connected parallel to the travel contactors. Auxiliary relay will release more quickly than the main contactors and the drive will be cut off without waiting for the release of the main contactors.

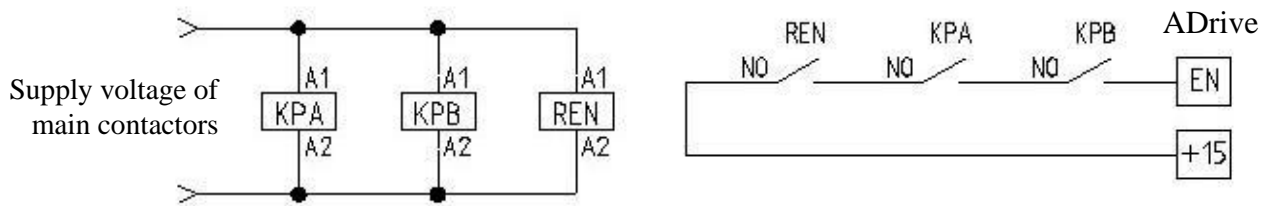

It is appropriate to use auxiliary relay which has less than 25ms contact release time.

13.2.2. Control input-output signals:

13.2.2.1. Relay outputs:

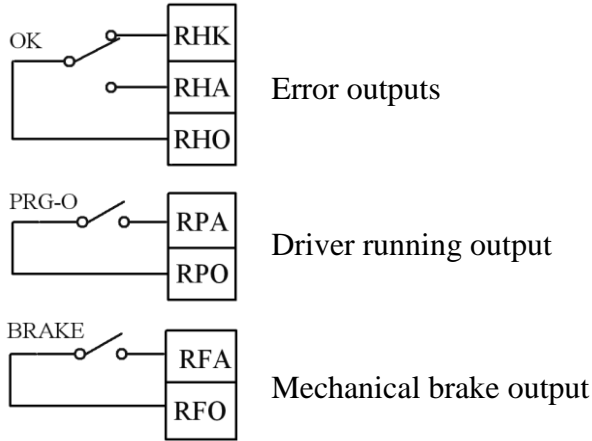

Relay output specifications:	
Output type	Potential-free contact
Max. switching capacity	10A/250VAC, 10A/30V DC
Clamping range	Max. 2,5 mm ²

Relay output terminals:		
RHK	Error relay NC contact	Error output. In normal situation the relay remains activated. In the event of a failure, the relay will be released. In order to cut off the error signal in case of a failure use the NO contact outputs (RHO-RHA).
RHA	Error relay NO contact	
RHO	Error relay COM contact	
RPA	Driver running relay NO contact	Driver running signal output.
RPO	Driver running relay COM contact	This output should be used when the lift controller releases the main contactors with a release command coming from the inverter. The relay remains activated during the drive.
RFA	Mechanical brake relay NO contact	Mechanical brake contactor output.
RFO	Mechanical brake relay COM contact	The drive activates the relay in order to release the mechanical brake.

Note: It is recommended to protect inductive loads with noise-reducing circuits (i.e. varistors or AC filters for AC voltages, diodes for DC voltages).

Recommended mechanical brake connection:



According to EN 81-1, disconnection of the mechanical brake coils from electrical current must be ensured by at least two contactors. The main-contactors disconnecting the motor current may be used for this purpose also.

Recommended mechanical brake connection is shown below:

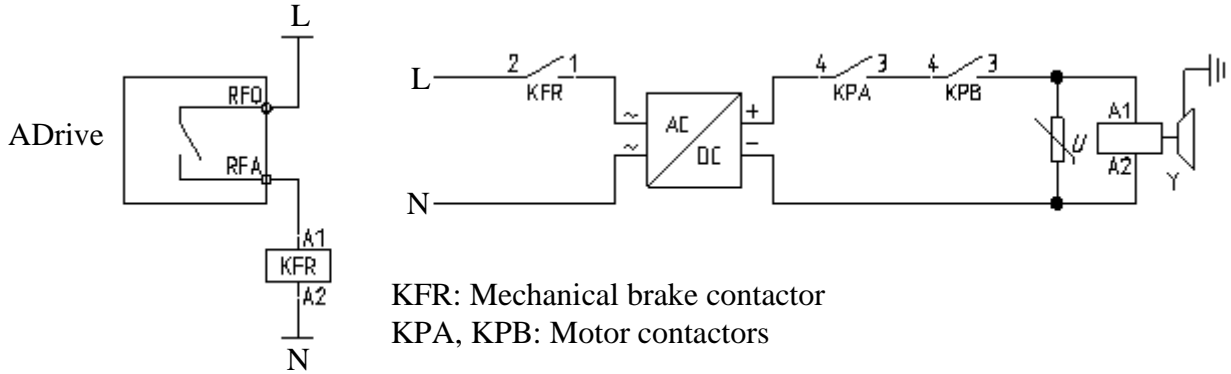

The main contactors (KPA and KPB) must be used to disconnect the DC supply of the mechanical brake. On the other hand, the brake contactor must be used to disconnect the AC supply. Disconnecting the DC supply directly while AC supply is still connected will cause arcs on the contact plates and will shorten the lifetime of the contacts. For that reason, the contacts on DC circuit must only be opened after the AC supply is cut-off. This will ensure that the contacts will only be used to disconnect the mechanical brake supply only in emergency situations.



Only the main terminals (not auxillary terminals) of the contactors must be used in the mechanical brake circuit.

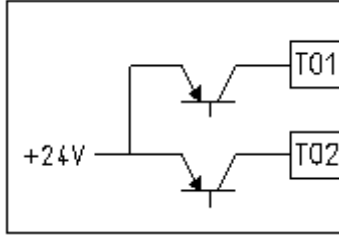

A suitable varistor must be used to filter the instantaneous high-voltage peaks on the brake coil.

13.2.2.2. Additional transistor outputs:

Transistor output specifications:	
Output type	Open collector
Output voltage	24VDC
Overload protection	Max. 200mA per output
Clamping range	Max. 2,5 mm ²

Additional transistor output terminals:		
TO1	Additional transistor output 1	Lower load direction (with lowest power consumption). This output is renewed during each brake releasing. TO1 = 24V: Direction UP (Car is lighter than counterweight) TO1 = Open: Direction DOWN (Car is heavier than counterweight)
TO2	Additional transistor output 2	V < 0,3 m/s. This output can be used for interlocking during run-in with open doors. TO2 = 24V: V < 0,3 m/s TO2 = Open: V >= 0,3 m/s

Note: 0 or -24V terminals on ADrive processor board may be used as common (GND) of additional transistor outputs.

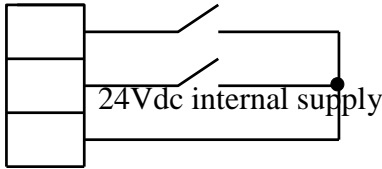
13.2.2.3. Additional digital inputs:

Digital input specifications:	
Max. voltage	26Vdc
Clamping range	Max. 2,5 mm ²

Additional input terminals:		
CI1	Additional input 1	Activation input for battery operation. When 24Vdc is applied to this input, inverter goes into battery operation mode. ⚠ This input must not be activated when the 3-phase AC supply is connected to inverter. For more information about battery-operated evacuation see Chapter 13.3.
CI2	Additional input 2	This input is reserved for future use.

Note: Additional inputs (CI1, CI2) and outputs (TO1, TO2) are available in version V2.5 and higher of processor board.

13.2.3. Incremental encoder connection for asynchronous motors

Incremental encoder connection for closed loop asynchronous drive is made to the terminals on the ADrive.

Encoder connection terminals:		
\bar{A}	Encoder -A	Encoder phase A inverse
A	Encoder A	Encoder phase A
\bar{B}	Encoder -B	Encoder phase B inverse
B	Encoder B	Encoder phase B
JP	Jumper (+7.5V)	The unused encoder phase terminals (A inverse and B inverse) must bridged to this terminal (for HTL Encoder)
+15V	+15V Supply	Supply voltage for HTL Encoder (Imax: 200 mA)
+5V	+5V Supply	Supply voltage for TTL Encoder (Imax: 400 mA)
0V	0V	Supply ground



Before connecting the encoder, observe encoder operating voltage and switch off the inverter.



Use a shielded cable for connection. Do not ground the encoder through both the motor and inverter. If the encoder is isolated from the motor, and from ground, then connect the cable shield to the inverter housing.



Motor cable and encoder cable channels should be separate. Minimum distance between cables should be at least 10cm.



To minimize the distortion, cable lengths should be as short as possible.

13.2.3.1. Incremental encoder simulation outputs:

If the lift controller needs the incremental encoder for shaft copying then use the simulation outputs on ADrive.

Incremental encoder simulation outputs:		
OA	Encoder A	Encoder phase A
OB	Encoder B	Encoder phase B

ADrive

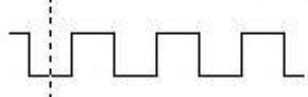

Output signal high: Max. 14V/10mA

Output signal low: Min. 1V/10mA

- The resolution of the encoder simulation outputs is identical with the encoder resolution.
- See the circuit diagram of ADrive simulation outputs for connection.

13.2.3.2. Incremental encoder connection examples:

Below in the connection diagram, most of commonly used encoder types are shown. Please contact authorized seller for different types of encoder. Also the electrical diagram of encoder input circuit will help to arrange different types of encoder.

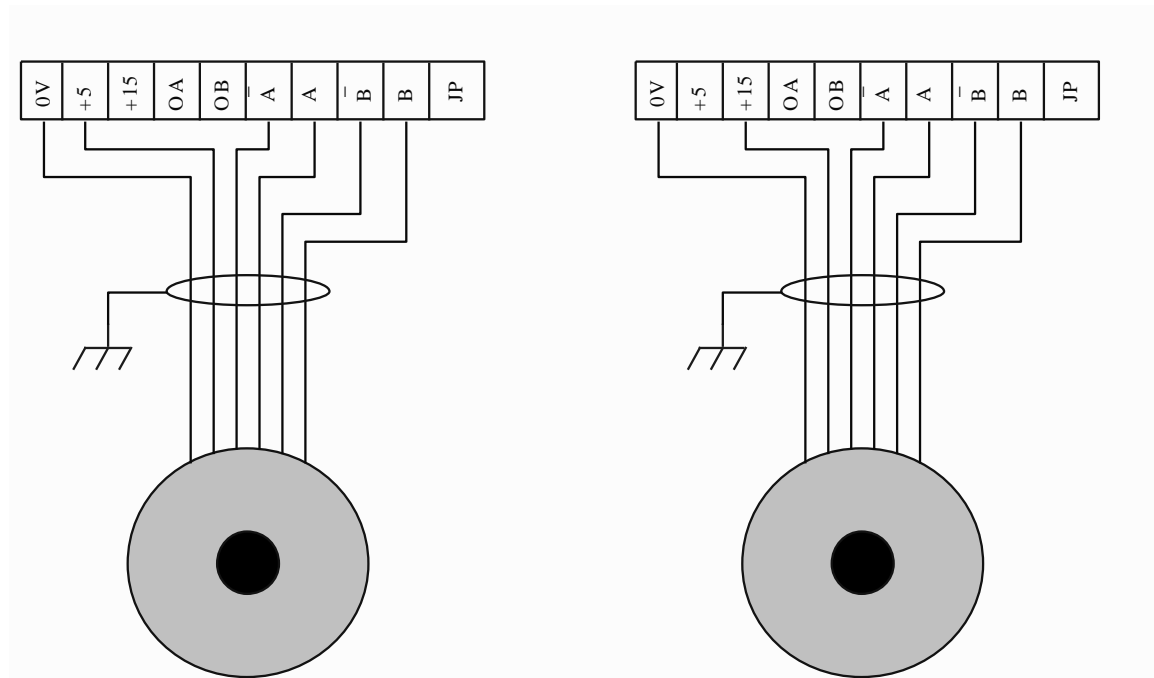

5V TTL ENCODER WITH COMPLEMENTAL OUTPUTS

12-24V HTL ENCODER WITH COMPLEMENTAL OUTPUTS

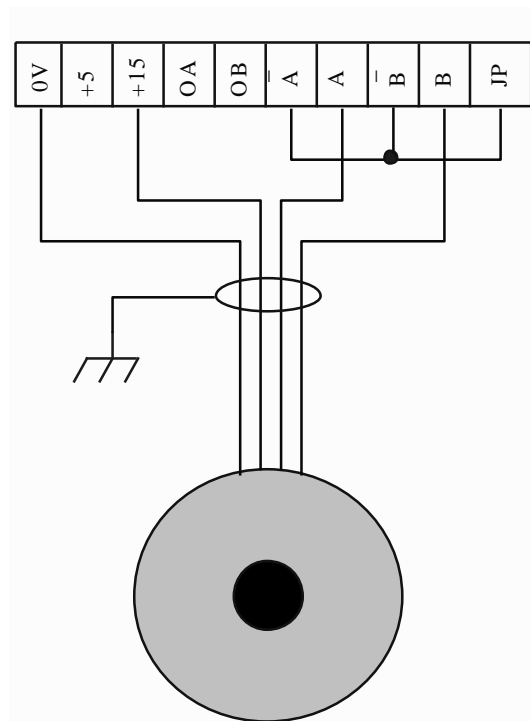

12-24V HTL ENCODER WITH SINGLE OUTPUTS

13.2.3.3. ADrive incremental encoder input circuit

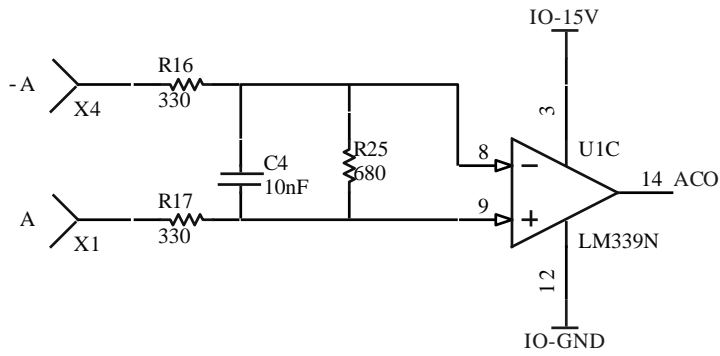
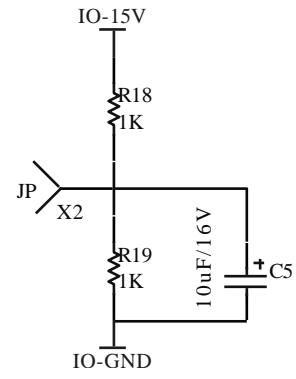
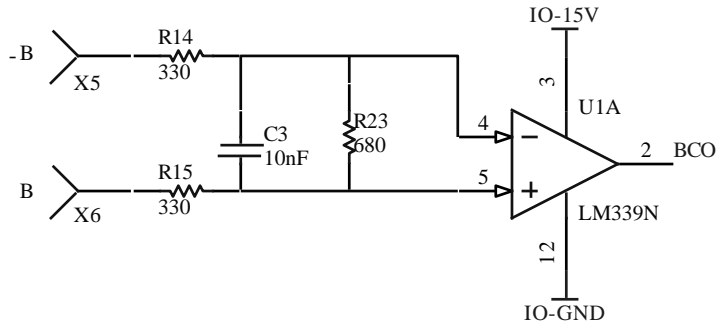

13.2.3.4. ADrive incremental encoder simulation output circuit

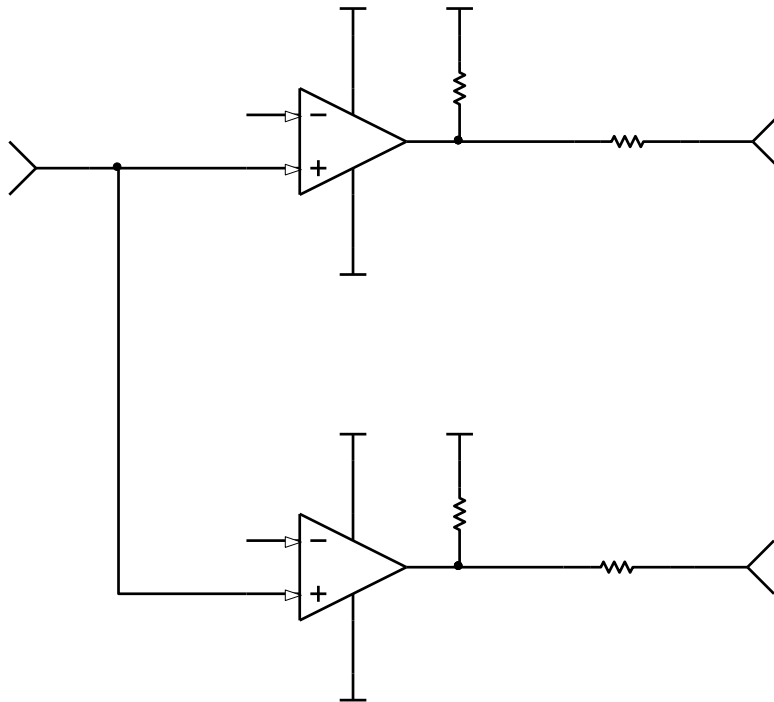

13.2.4. Absolute encoder connection for synchronous motors

A Drive supports absolute value encoders with EnDat, SSI and SinCos interface. The absolute encoder connection for synchronous motors is made to ENCABIT-Plus module which is externally mounted to the device for synchronous applications.

Technical specifications of absolute encoder inputs:		
Encoder interface type	EnDat 2.1 SSI (*) SinCos (*)	Encoder type is selected by the parameter 2.21.
Encoder resolution	2048 pulse/revolution	
Encoder supply voltage	5Vdc ± %5	
Max. supply current	400mA	
Connection type	<ul style="list-style-type: none"> to 3-row 15-pole SUB-D female connector (for EnDat and SSI) to terminal strips (for EnDat, SSI and SinCos) 	

*: SSI and SinCos absolute value encoders are supported with firmware version >= 8.52. For older versions, a firmware update must be performed.

13.2.4.1. Encoder connection with X-ENC1 connector (for EnDat and SSI encoders):

This connection method is suggested when the encoder connection cable has a ready-made 15-pole SUB-D connector on driver side-end and the pin configuration of the SUB-D connector corresponds to ENCABIT-Plus module. The pin assignment of X-ENC1 connector is shown in the table below.

X-ENC1 connector can only be used for encoders with EnDat and SSI interface. SinCos encoder connection must be made to the related terminals on ENCABIT-Plus.

X-ENC1 connector pin assignment	Encoder wires (EnDat or SSI encoder)
1	A+
2	A-
3	B+
4	B-
5	Data+
6	Data-
11	Clock+
12	Clock-
13	5V (Up), 5V (Sensor) (*)
14	0V (Un), 0V (Sensor) (*)

*: It is recommended to connect the encoder wires 5V (Sensor) and 0V (sensor) in parallel to terminals 5V (Up) and 0V (Un).

 The metal casing of X-ENC1 socket is NOT earthed. Do not use the socket casing for earthing purposes.

 Refer to the statements given in 13.2.4.3 for encoder connection.

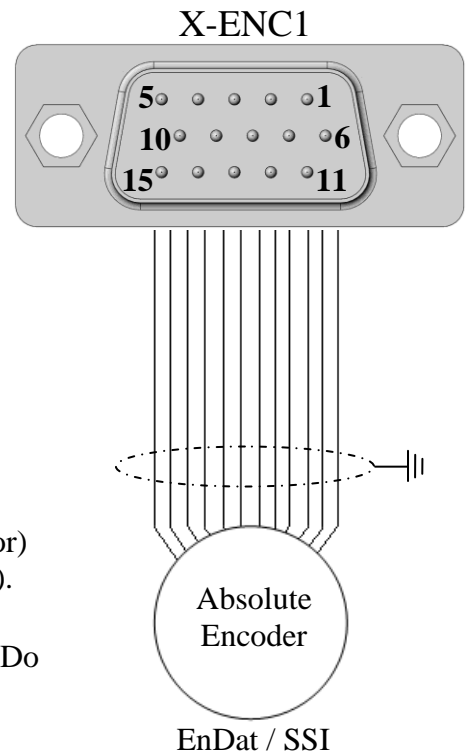

13.2.4.2. Encoder connection with terminal strips (for EnDat, SSI and SinCos encoders):

If the encoder connection cable has no ready-made SUB-D connector on driver side end, you can use the terminals on the ENCABIT-Plus module. Make the connection in accordance with the description shown below.

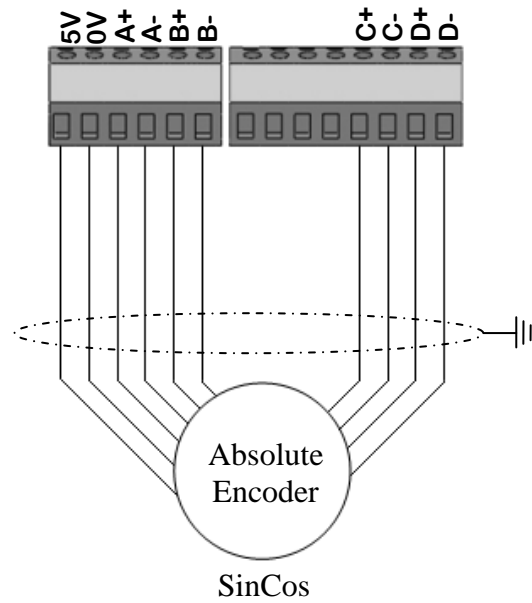
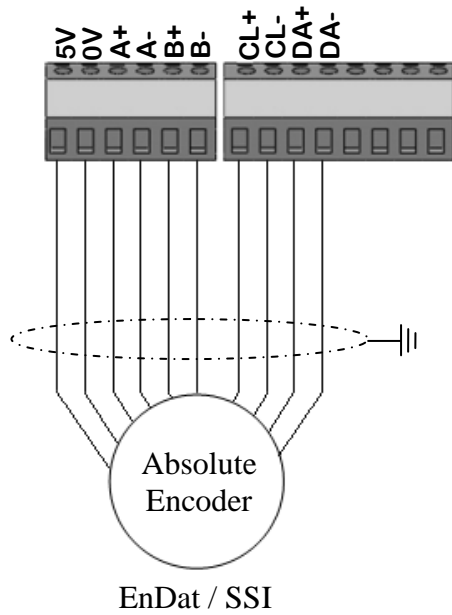

Terminals on ENCABIT-Plus	Encoder wires	
	EnDat or SSI encoder	SinCos encoder
A+	A+	A+
A-	A-	A-
B+	B+	B+
B-	B-	B-
DA+	Data+	
DA-	Data-	
CL+	Clock+	
CL-	Clock-	
D+		D+
D-		D-
C+		C+
C-		C-
5V	5V (Up), 5V (Sensor) (*)	5V (Up), 5V (Sensor)
0V	0V (Un), 0V (Sensor) (*)	0V (Un), 0V (Sensor)

*: It is recommended to connect the encoder wires 5V (Sensor) and 0V (sensor) in parallel to terminals 5V (Up) and 0V (Un).



There is no terminal on the encoder terminal group to earth the encoder cable screen. If earthing the cable screen is needed, use the earthing terminal located on the device.



Refer to the statements given in 13.2.4.3 for encoder connection.

13.2.4.3. Consider the following statements when connecting the encoder:

The inverter must be switched off before connecting the encoder.



The motor must be properly grounded before connecting the encoder.



Do not ground the encoder through both the motor and inverter side. If the encoder is isolated from the motor, and from ground, then connect the cable shield to the grounding conductor on the inverter.



When connecting the encoder cable with SUB-D connector, please ensure that the pin configuration of the encoder cable corresponds to the pin configuration of the ENCABIT-Plus module. Faulty connection may cause un-repairable damage to the encoder or the inverter.



The connection cable of encoder may never be unplugged or removed under voltage. Make sure the socket is connected tightly.



Motor cable and encoder cable channels should be separate. Minimum distance between cables should be at least 10cm.



To minimize the distortion, cable lengths should be as short as possible.

13.2.4.4. Absolute encoder simulation outputs:

If the lift controller needs the absolute encoder for shaft copying then use the absolute encoder simulation outputs on ENCABIT-Plus module.

Absolute encoder simulation outputs:		
QA-	Encoder -A	Encoder phase A inverse
QA	Encoder A	Encoder phase A (+24V)
QB-	Encoder -B	Encoder phase B inverse
QB	Encoder B	Encoder phase B (+24V)

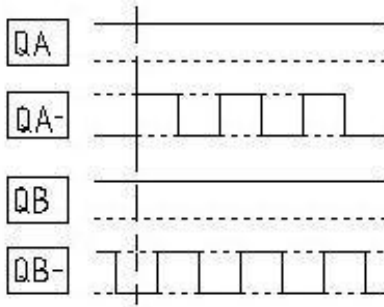

Output signal high: Max. 24V (max. 100mA)
Output signal low: Min. 0.6V

- The resolution of the encoder simulation outputs is identical with the encoder resolution.



Use a shielded twisted pair cable for connection. Connect the cable shield to the inverter housing.



To minimize the distortion, cable lengths should be as short as possible.



Encoder simulation cable channel should be separated from motor and other power cables. Minimum distance between cables should be at least 10cm.

ENCABIT-Plus absolute encoder simulation output circuit:

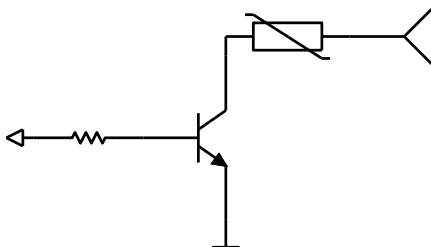
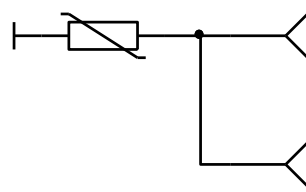
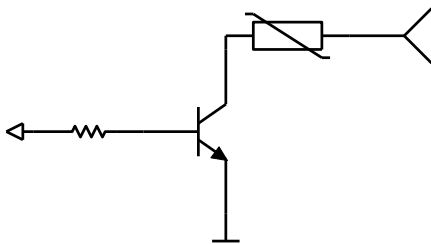

13.2.5. Mechanical brake release monitoring

For synchronous drives, the switching state of the mechanical brakes must be monitored against uncontrolled car movements. The brake release monitoring micro-switches are connected to **PI1** input on ENCABIT-Plus module.

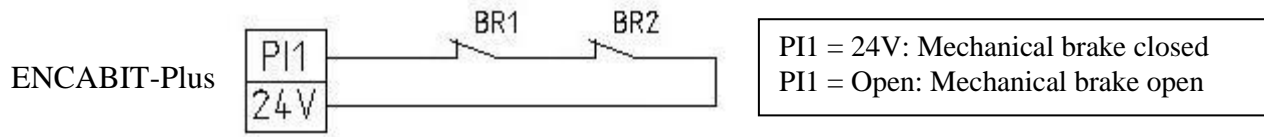

BR1: 1st mech. brake release monitoring normally closed contact (NC)
BR2: 2nd mech. brake release monitoring normally closed contact (NC)

- If the brake release monitoring function will be used, the parameter “11.6-Brake monitoring” must be enabled.

13.2.6. Motor & brake resistor temperature monitoring

Motor & brake resistor temperature monitoring can be carried out by ADrive (usually when the inverter and the lift controller are located in separate places). Temperature monitoring connection is made to **PI2** input on ENCABIT-Plus module.

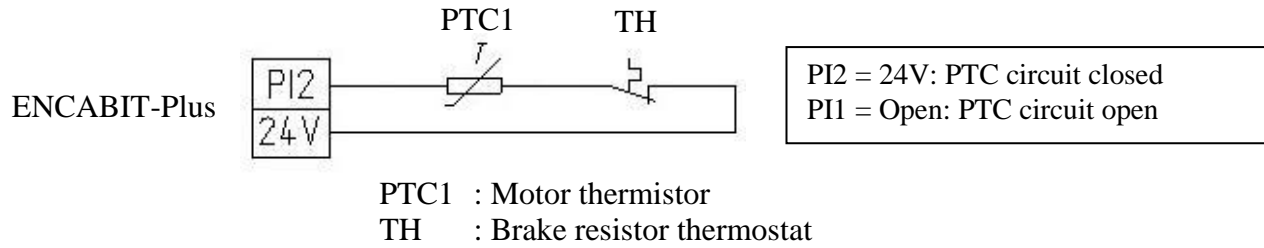

- If the temperature monitoring function will be used, the parameter “11.7-PTC check” must be enabled.

13.2.7. Manual evacuation mode activation input

A Drive can be informed that the manual evacuation mode is active, through a high level at the PI3 input on ENCABIT-Plus module.

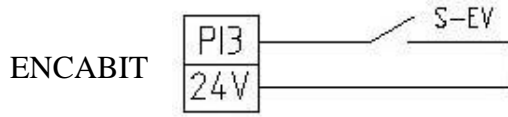

S-EV: NO contact of manual evacuation mode activation switch

When the input PI3 is activated, a special evacuation screen appears on A Drive display. A similar screen is also appears on A Drive Remote Keypad display. The following information is shown in the manual evacuation mode screen:

- The direction of car
- The speed of car
- Over speed warning (The evacuation speed must not exceed 0.63 m/s)

SPEED : 0.4 m/s
DIR : ↑

When the manual evacuation mode is activated, the speed (m / s) is shown on the top line and the direction (↑ or ↓) is shown on the bottom line of the evacuation screen.

SPEED : 0.65 m/s
STOP!!! (V>0.63)

When the evacuation speed exceeds 0.63 m/s, a warning message will be shown on the bottom line of the evacuation screen. In such a case, the operation must be stopped.



According to EN 81-1/A2 6.6.2.c, during emergency evacuation, the following information must be given in cases that the drive machine cannot be observed directly:

- The direction of car
- The speed of car
- Door unlocking zone

We recommend using one of ARKEL products LEVELED board for indicating the door unlocking zone information.

13.2.8. External 24V power supply

An external 24V power supply can be applied to +/- 24V terminals on ADrive. In this way even in case of mains failure the processor unit of ADrive and ENCABIT-Plus module remain active.



In synchronous applications external 24V power supply is required! External 24V supply must not be interrupted even in case of mains failure, in order to read the absolute encoder data and to enable the evacuation screen in manual or automatic evacuation mode.

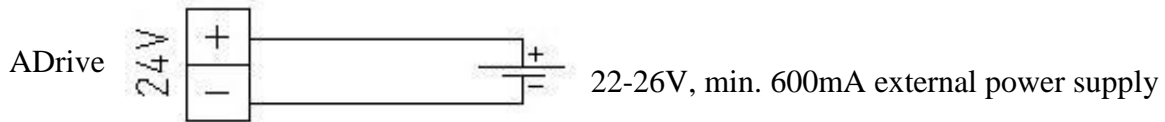

The following functions remain active with external power supply even when mains power is off:

- On ADrive inverter:
 - Drive command inputs and relay outputs
 - Incremental encoder inputs and simulation outputs
 - RS-485 serial communication protocol (communication with ADrive Remote Keypad or ARL-500 lift controller)
 - CANbus connection with ENCABIT-Plus module
- On ENCABIT-Plus module:
 - Digital inputs and transistor outputs
 - Absolute encoder inputs and simulation outputs

13.2.9. The connection between ENCABIT-Plus module and ADrive

The connection between ADrive and ENCABIT-Plus module is done with a cable with sockets at both ends. The communication is provided through CANbus serial communication protocol.

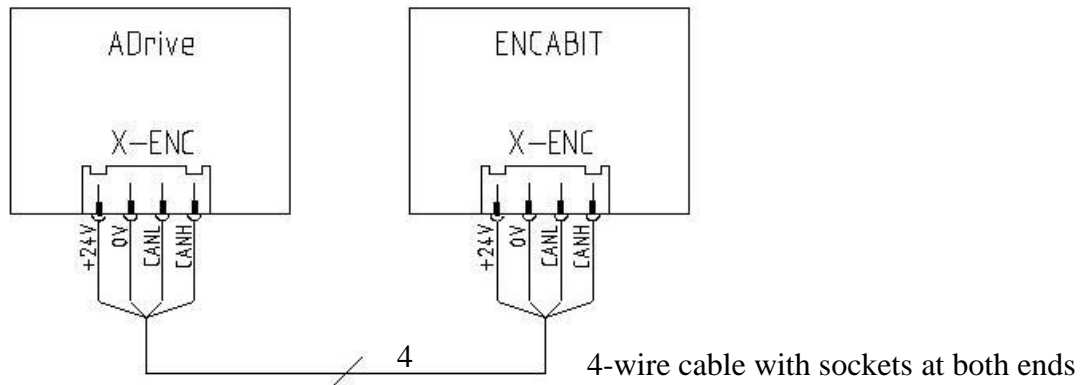

X-ENC connector pin assignments:	
+24V	24V power supply terminals (+24V: red, 0V: black)
0V	
CANL	CANbus communication terminals (CANL: green, CANH: yellow)
CANH	

13.2.10. Inputs/Outputs on ENCABIT-Plus module

ENCABIT-Plus module provides an absolute encoder connection as well as 5 digital inputs and 2 transistor outputs. Inputs and outputs are reserved for functions required for synchronous drives.

13.2.10.1. ENCABIT-Plus digital inputs:

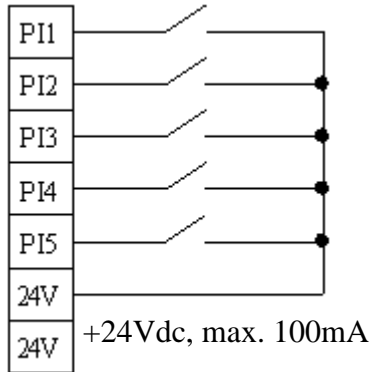

Digital input specifications:	
Max. voltage	26Vdc
Clamping range	Max. 1,5 mm ²

ENCABIT-Plus digital input terminals		
PI1	Input 1	Mechanical brake release monitoring (Can be activated in the menu)
PI2	Input 2	Motor & brake resistor temperature monitoring (Can be activated in the menu)
PI3	Input 3	Manual evacuation mode activation input
PI4	Input 4	Reserved input
PI5	Input 5	Reserved input
24V	+24Vdc reference voltage	Reference voltage for digital inputs
24V		

13.2.10.2. ENCABIT-Plus transistor outputs:

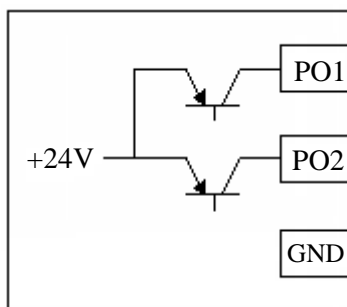

Transistor output specifications:	
Output type	Open collector
Output voltage	24VDC
Overload protection	Max. 200mA per output
Clamping range	Max. 1,5 mm ²

ENCABIT-Plus transistor output terminals:		
PO1	Transistor output 1	Reserved output
PO2	Transistor output 2	Reserved output
GND	OVdc	Common of transistor outputs

13.2.11. Serial communication with ARL-500 Lift Controller

This serial communication is an RS-485 protocol designed specifically for ARL-500 lift controller for data exchange between ADrive and ARL-500. It is used instead of parallel signals and also for remote control of ADrive from ARL-500 controller. The RS-485 jack (RJ-45) on ADrive is used for this serial connection. To make this the serial connection, ARL-500 control panel must be equipped with the optional module CNV500 RS-232 to RS-485 convertor module.



Serial communication with ARL-500

Cable type:
Standart CAT5 network cable

The following connections are not necessary between ARL-500 lift controller and ADrive inverter when the serial connection is made.

- Speed inputs (V0, V1, V2, V3)
- Direction inputs (UP, DWN)
- Error output (RHO-RHA)
- Driver running output (RPO-RPA)
- Encoder simulation outputs
- ADrive remote keypad connection

13.2.12. ADrive Remote Keypad Connection

ADrive Remote Keypad is an external remote control terminal used when direct access to ADrive control panel is not possible. All adjustments can be made remotely from the keypad panel. The connection of ADrive Remote Keypad is made to RS-485 connector on ADrive with a standard CAT5 network cable. Supply voltage is provided via this cable, there is no need to use an external power source for the keypad. If an external 24V power supply is applied to ADrive, even in case of mains failure the remote keypad remains active.

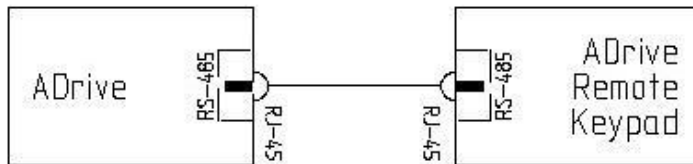

ADrive Remote Keypad connection

Cable type:
Standart CAT5 network cable

13.3. EMERGENCY EVACUATION OPERATION

A Drive is capable of performing an automatic evacuation by driving the motor with connection of a set of batteries or a 1-phase 230Vac UPS in case of a mains power failure.



Evacuation operation with back-up power is supported only for **closed-loop** operation.



This feature is available in version V2.5 and higher of processor board.

13.3.1. General information:

For emergency evacuation in case of power failure, an external power supply is required to supply the components in the elevator system (elevator control unit, mechanical brakes, retiring cam, door operator ...) with sufficient power. Thus, a UPS is needed in all applications. Therefore, there are two ways of supplying back-up power to the elevator control system for evacuation operation with A Drive inverter.

1st way	For motor power: Min. 60Vdc battery voltage For other units (except motor power): 1-phase 230Vac UPS
2nd way	1-phase 230Vac UPS (for whole system including the motor power)

The selection of power supply for evacuation operation depends on the type of the evacuation method (evacuation in the lower load direction or command direction given by the lift controller).

If the evacuation operation is performed in the lower load direction, 60Vdc battery back-up supply will be sufficient.

If the evacuation operation is performed in the command direction given by the lift controller (not in the lower load direction), because the required power for moving the car is increased, a battery pack with higher voltage (72-120Vdc) or a 1-phase 230Vac UPS with a sufficient power is needed.

13.3.2. Required back-up power supplies:

In evacuation operation, two dc supplies must be provided to the inverter as follows:

The connection of the back-up power has to be carried out in accordance with the specifications described in the Chapter 13.3.5.

The power circuit supply:

This provides just the power for the motor during evacuation operation. The power circuit of the inverter can either be supplied by batteries or by a UPS.

This supply must be connected to the input terminals L1 and L3.

The back-up power connected to the inverter is set by the parameter “**12.1** Battery voltage”.

The control circuit supply (24Vdc):

This provides just the power for control circuits when the AC supply is not present. This supply must be permanently connected to the +/-24V input terminals on the inverter.

13.3.3. Evacuation in the lower load direction:

Performing the evacuation in the lower load direction can help to minimize the power requirement during the evacuation operation. It is highly recommended to use this facility when the evacuation direction is not mandatory.

During each travel, ADrive determines the lower-load direction which depends on the weight imbalance between the car and the counter-weight. This information is output from TO1 terminal and it may be used by external devices which need this information.

Method of “Evacuation in the lower-load direction” maybe activated or deactivated by the “12.2-DIRECTION” parameter.

- On evacuation, if 12.2 parameter is set to “BD:EASIEST DIR.”, ADrive will ignore the direction command from the controller and will move automatically towards the “lower-load direction”
- If 12.2 parameter is set to “BD:COMMAND DIR.”, TO1 lower-load direction output must be read by the controller and the controller must give the appropriate evacuation direction command to the driver.

During evacuation, exact stopping point depends on the car-load. The floor level may be missed slightly.

13.3.3.1. Back-up Power Requirement Calculations for Evacuation Towards Lower-Load Direction:

As the car will be moved in the same direction in which the gravity forces the system to move, the back-up power will only be used to slow down the car and (if the system is nearly balanced) to accelerate the car.

If the travel speed on evacuation is set too low, this will elongate the travel time and will cause the brake coil to consume energy for a longer period. Because of this, setting the evacuation speed to a value between % 15 and % 35 of nominal motor speed is recommended. Evacuation speed is limited by “12.3-BAT.Speed” (V4) parameter. Even if it is possible to move faster by back-up power, the driver will not allow the car to exceed the speed set by this parameter.

If the distances between floor levels are long, the evacuation time will be long which means the power consumption will be higher. While calculating the back-up power requirements, this fact must also be considered.

The voltage of the connected back-up power must be set in the parameter “12.1-BAT.VOLTAGE”.

a) With battery supply:

60 VDC battery voltage is sufficient. While determining the capacity required for the batteries, a rule of thumb is, choosing the batteries such that battery capacity in Ah's will be at least 1/3rd of the motor current in A's. For example; at least a 7Ah battery must be used for a 21A motor.

b) With UPS Supply:

A UPS having the power of 1/5th of the motor power should be sufficient. For example: A 1.1kW UPS may be used for a 5.5kW motor.

The power that will be drawn from the UPS must be limited by “12.4-UPS POWER” parameter. If power is not limited, the UPS may be overloaded.

If the UPS will also power other electrical loads during evacuation (i.e: control panel, mechanical brakes, door operator, etc), the power required by those loads must also be considered on calculation of the UPS power.

13.3.4. Evacuation Towards Command Direction:

This method must be used if evacuation is required to finish on a certain predetermined floor.

If “Evacuation Towards Command Direction” is required, “12.2-DIRECTION” parameter must be set to “BD:COMMAND DIR.”. In that case, the driver will move the car towards the direction commanded by the controller.

On “Evacuation Towards Commanded Direction”, movement direction is independent of the car-load. The car is moved in the desired direction and is stopped exactly on floor level.

13.3.4.1. Back-up Power Requirement Calculations for Evacuation Towards Lower-Load Direction:

On “Evacuation Towards Commanded Direction”, the worst case scenarios are when the command is up with a fully-loaded car or when the command is down with an empty car. Therefore, auxiliary power requirement calculations must be made considering these scenarios.

Using a low speed setting for evacuation, will reduce instantaneous power requirements but will increase evacuation duration. Likewise, using a high speed setting will increase the instantaneous power requirements while reducing the evacuation duration. Evacuation speed may be limited by “12.3-BAT.Speed” parameter. The driver will not allow the car to exceed this speed limit even if the system allows moving faster.

If the distances between floor levels are long, the evacuation time will be long which means the power consumption will be higher. While calculating the back-up power requirements, this fact must also be considered.

The voltage of the connected back-up power must be set in the parameter “12.1-BAT.VOLTAGE”.

a) With battery supply:

It is recommended to apply as 72VDC – 120VDC battery voltage. While determining the capacity required for the batteries, a rule of thumb is, choosing the batteries such that battery capacity in Ah's will be at least 1/3rd of the motor current in A's. For example; at least a 7Ah battery must be used for a 21A motor.

b) With UPS Supply:

Assuming the evacuation speed to limited to 1/4th of nominal motor speed; a rule of thumb is to use a UPS with power rating of at least half the motor power. For example: A 5 kW UPS may be used for a 10 kW motor.

In reality, the exact power requirement of the UPS is dependent on many factors including shaft efficiency, evacuation speed and motor plate values. The best way to determine the exact requirements is to find it empirically. While measuring the power requirements, the following procedure may be used:

- Instead of a UPS, mains power is supplied to the real system
- Car is unloaded
- Evacuation speed limit is set by the “12.3-BAT.Speed” parameter (recommended to set it to 1/4th of nominal speed)
- The current drawn from mains during evacuation in downwards direction is measured.

Minimum required power (W) = 220 V x Measured current (A)

Minimum required power (VA) = 220 V x Measured current (A) x 1.4

The UPS should be chosen such that its power rating is at least 1.3 times the calculated minimum power requirement.

The power that will be drawn from the UPS must be limited by “12.4-UPS POWER” parameter. If power is not limited, the UPS may be overloaded.

If the UPS will also power other electrical loads during evacuation (i.e: control panel, mechanical brakes, door operator, etc), the power required by those loads must also be considered on calculation of the UPS power.

13.3.5. Back-up power wirings for evacuation operation:

The back-up power supply connections are shown in this section.

13.3.5.1. With battery supply:

The battery supply must be connected to the input terminals L1 and L3.



Do not make different connection. Otherwise the device may be damaged.

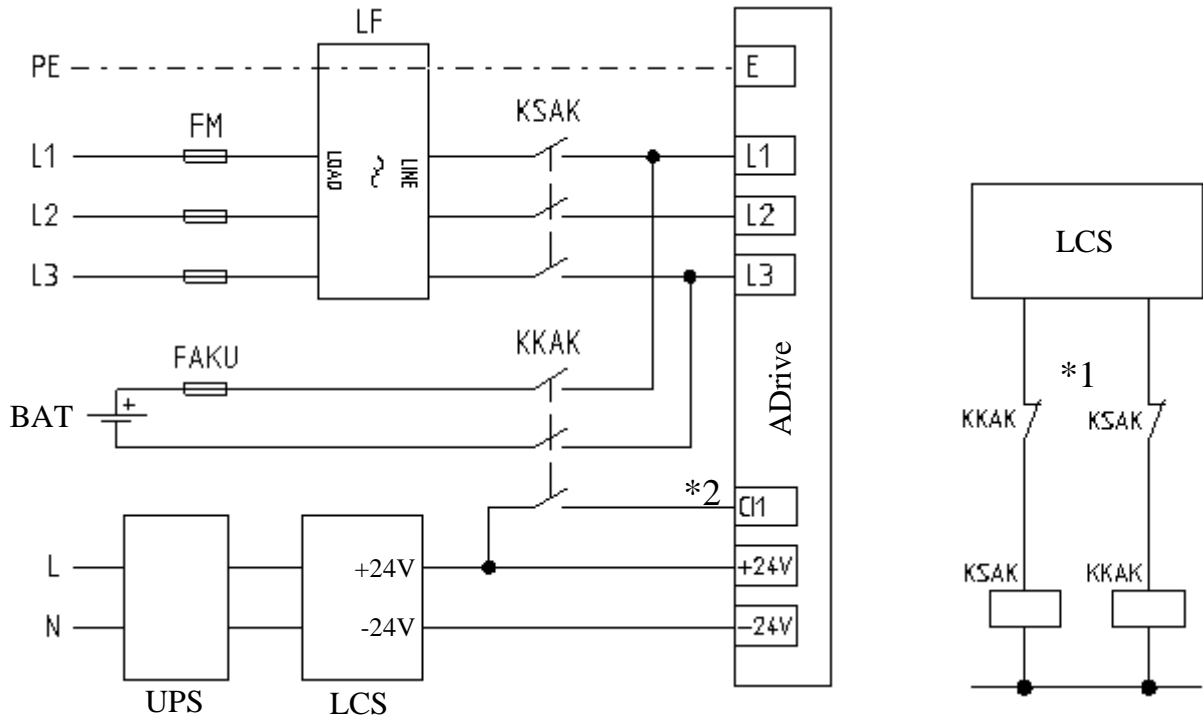

FM: Mains fuse

LF: Line filter

BAT: Batteries

UPS: 1-phase 220Vac uninterruptible power supply

LCS: Lift control system

FAKU: Battery fuse

KSAK: Mains supply contactor

KKAK: Battery supply contactor

*1: Contactor KSAK and KKAK must be interlocked.

*2: Activation of for battery operation (CI1 input).



See Chapter 6 for appropriate fuse, contactor and cable cross-section.

13.3.5.2. With UPS Supply:

UPS must be connected to the input terminals L1 and L3.

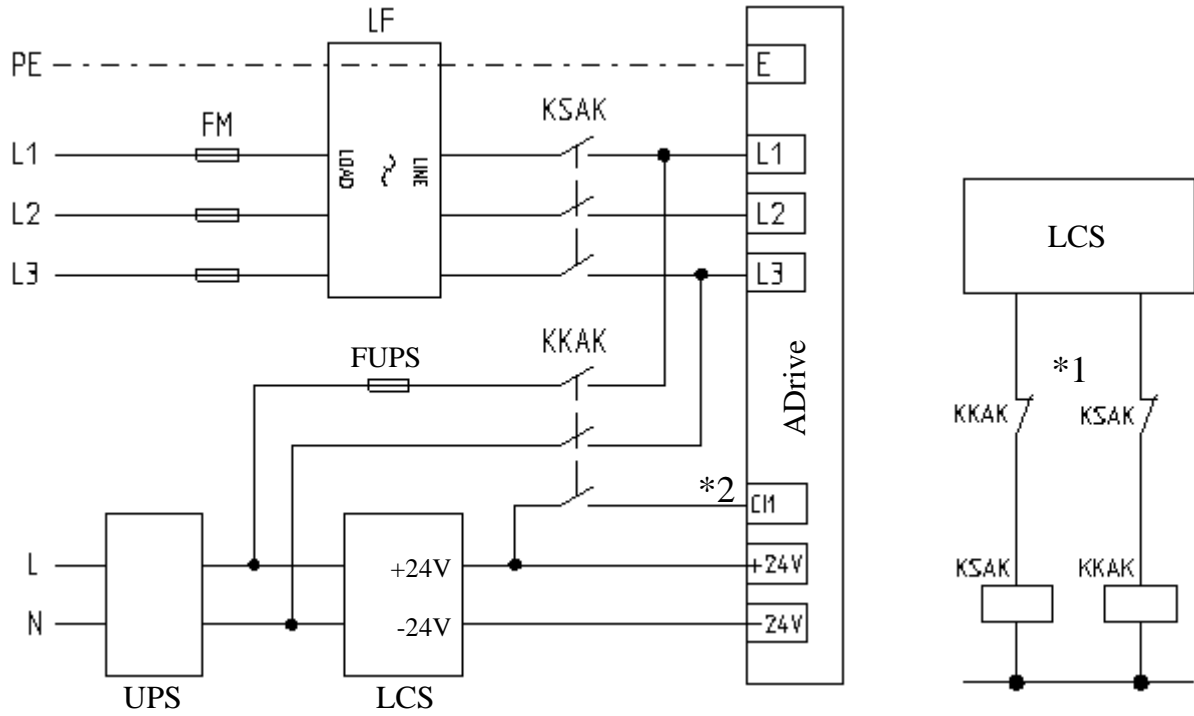

FM: Mains fuse

LF: Line filter

UPS: 1-phase 220Vac uninterruptible power supply

LCS: Lift control system

FUPS: UPS fuse

KSAK: Mains supply contactor

KKAK: Battery supply contactor

*1: Contactor KSAK and KKAK must be interlocked.

*2: Activation of for battery operation (C11 input).



See Chapter 6 for appropriate fuse, contactor and cable cross-section.

13.3.6. Process of an evacuation travel:

The elevator controller must be capable of performing an evacuation operation in case of a power failure. The following operations must be carried out respectively by the elevator control system:

- Control detects mains failure.
- Control recognizes inverter fault.
- Control waits a certain time for the mains power to restore or for a generator to go online.
- Control disconnects the mains supply from inverter by releasing the KSAK contactor.
- Control activates the KKAK contactor after a certain time (**t1**: minimum 2s):
 - This connects the back-up power supply to the input terminals L1 and L3.
 - This activates the input terminal CI1. Inverter goes into an evacuation operation mode and inverter fault is cleared.
- Control recognizes that the inverter is ready (no fault).
- Control activates the drive ENABLE signal (input terminal EN) by activating the main contactors (KPA and KPB).
- Control applies the speed and direction command to the inverter.
 - If the parameter “12.2-DIRECTION” is set as “BD: EASIEST DIR”:
 - Inverter ignores the applied speed and direction commands and starts running the motor in the optimum direction (easy direction) with a maximum speed limited with V4 speed.
 - If the parameter “12.2-DIRECTION” is set as “BD: COMMAND DIR”:
 - Inverter ignores only the applied speed command and starts running the motor in the direction applied with a maximum speed limited with V4 speed.
- Control deactivates the evacuation operation after the trip is completed with the following sequence:
 - Control releases the KKAK contactor:
 - This disconnects the back-up power supply from the inverter.
 - This deactivates the input terminal CI1. Inverter goes into a normal operation mode.
 - Control reconnects the mains power to the inverter by activating the KSAK contactor after a certain time (**t2**: minimum 1s).

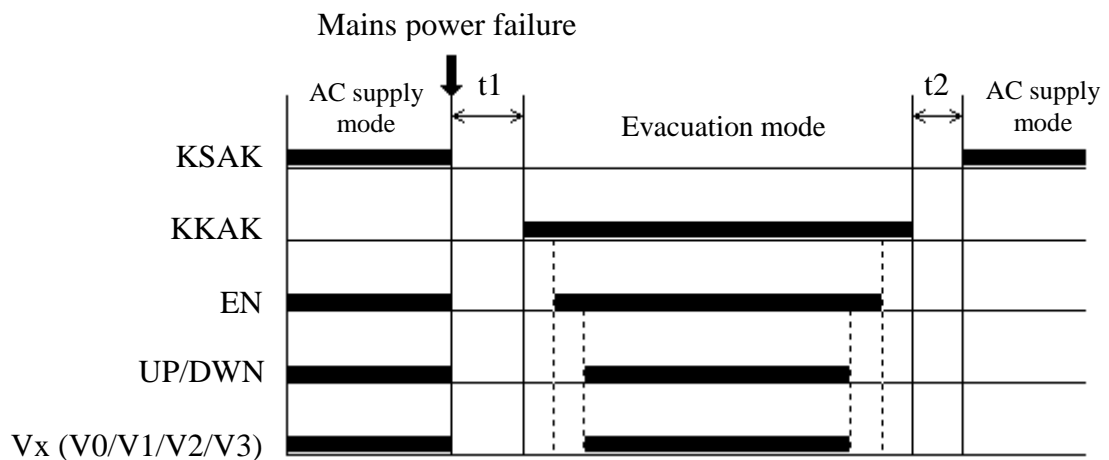

14. PC Connection

It is possible to connect ADrive Inverter to a PC over the RS-232 serial communication port with a proper cable. It is a standard RS-232 PC connection cable. Any standard RS-232 cable can be used instead of the original cable supplied with ADrive. A **USB** to **RS-232** 9-pin adapter is required for Laptop connection via **USB** port. ADrive PC connection is shown below:

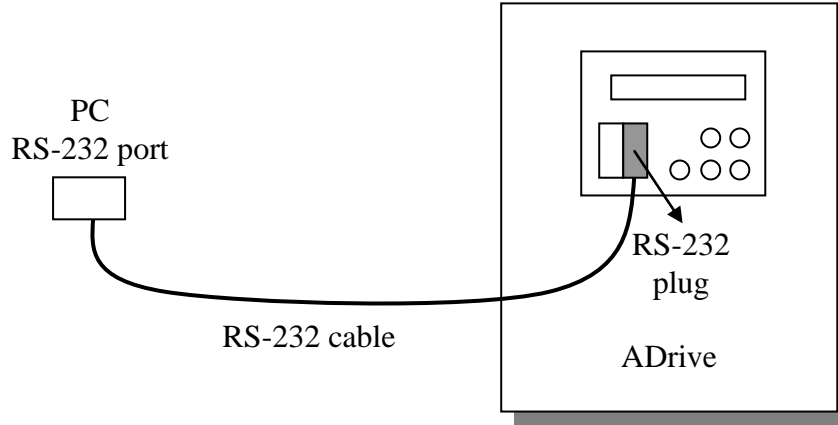

14.1. ADrive-Win Simulator & Monitor Software

ADrive-Win simulator/monitor software is used with ADrive for travel curve simulation, monitoring data and transferring parameters.

Detail information is given in the *ADrive-Win User Manual*.

14.2. Firmware Upgrading

It is possible to upgrade ADrive's firmware via ARKEL Firmware Updater software. By this way new features/facilities can be added to the product.

ARKEL Firmware Updater is an utility software which connects your computer and the device, enabling you to load the firmware file to your device.

The device firmware file is not a part of this software. The latest firmware file which is compatible with device can be downloaded from our web site. Before downloading firmware you must learn your device firmware version. The firmware version is displayed on device screen while starting up. If your device firmware is already the latest version, it is not necessary to perform this update. Firmware updates can only be applied to devices with firmware versions later than V8.00.

An ADrive firmware file also includes the firmware of ENCABIT-Plus module. ADrive will automatically update the ENCABIT-Plus module after the power is switched off and on again.

Detail information is given in the *Arkel Firmware Updater User Manual*.

15. Data Key

The Data Key which is memory device and comes with ADrive can save parameters from the ADrive Inverter or can transfer the parameters inside to the ADrive Inverter.

The plug on ADrive which is used for Data Key connection is 9-pin D-type male. Do not use this plug for PC connection.



Data Key

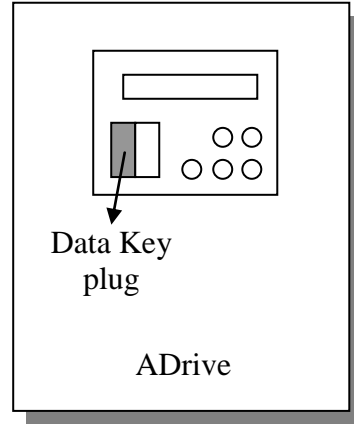

Data Key
plug



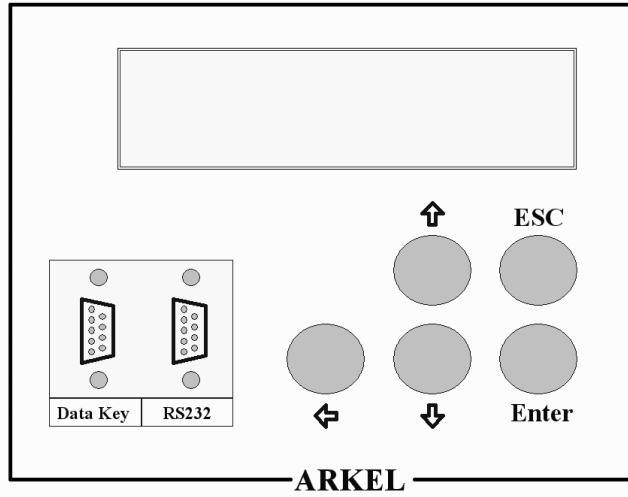

ADrive

16. LCD SCREEN AND KEYPAD USAGE



ADrive user panel

ADrive has an LCD screen with 2-row / 16-character and 5-key keypad. These buttons function as follows:

	Enter menu/submenu Select parameter / edit value
	Exit menu/submenu
	To next / previous monitoring screen To next / previous parameter
	Increase / decrease parameter value
	Change digit of parameter value

1.1. STARTUP SCREEN

ADrive 7.5kW
SW:6.5 SN:63012

STARTUP SCREEN

After switching on, the startup screen is displayed. The information of ADrive power rating, software version (SW) and serial number (SN) are displayed on this screen.

After being displayed this screen for about 2 seconds, "MAIN SCREEN" is displayed.

16.2. MONITORING SCREENS

↑ and ↓ keys are used for changing the monitoring screens.

READY
RPM: 0 I: 0.0A

MAIN SCREEN (CLOSED LOOP)

Motor rpm (RPM) and motor current (I) are displayed on this screen.

READY
Vout: 0 I: 0.0A

MAIN SCREEN (OPEN LOOP)

Motor output voltage (Vout) and motor current (I) are displayed on this screen.

MOT.TEMPERATURE
%0

MOTOR TEMPERATURE SCREEN

Approximate motor temperature is displayed on this screen.

RPM : 0
*

RPM ERROR SCREEN (CLOSED LOOP)

Rpm error is displayed on this screen. This error is the difference between the inverter operation value and the encoder value. '*' sign indicates this difference by moving left-right. If '*' sign is at the right side of display, it means motor is running faster than inverter operates. If '*' sign is on the right side of display, motor is running slower than inverter's target speed.

Estimated rpm :
0 Rev./Minute

ESTIMATED RPM SCREEN (OPEN LOOP)

Approximate motor estimated rpm is displayed on this screen.

VBUS:50 F:0.0
Slip: 0.0 Hz

DC BUS / OUTPUT FREQUENCY SCREEN

The DC bus voltage (VBUS), the motor output frequency (F) and the rotor slip frequency (Slip) are displayed on this screen.

CS:002,003,002
IT:0000 YML 11KW

TECHNICAL SUPPORT SCREEN

This screen is only used by technical supporter.

TOTAL WORKING:
00004197 Minute

TOTAL WORKING TIME SCREEN

The total working time of driver in minutes is displayed on this screen.

TOTAL DISTANCE:
00003581 Meter

TOTAL TRAVEL DISTANCE SCREEN

The total travel distance of elevator in meters is displayed on this screen.

TOTAL TRAVEL:
0000358 RUN/STOP

TOTAL NUMBER OF TRAVEL SCREEN

The total number of travel of elevator in run/stop is displayed on this screen.

CAN_BUS: 1920 p/s
RS485 : 800 p/s

SERIAL COMMUNICATION MONITORING SCREEN

CAN_BUS: The number of packets per second of CANbus serial communication between ENCABIT-Plus module and ADrive.

RS485: The number of packets per second of RS-485 serial communication (with ADrive Remote Keypad or lift controllers)

Vref : 1.20 m/s
Vact: 1.19 m/s

SPEED MONITORING SCREEN

Vref: Reference (target) speed

Vact: Actual (current) speed

Encabit PI:01000
Enc_pos : 001A3f22

ENCABIT-Plus MONITORING SCREEN

Encabit PI: The state of the 5 digital inputs (PI1-PI5) on ENCABIT-Plus module (1: input active / 0: input inactive).

	PI1	PI2	PI3	PI4	PI5
Encabit PI:	0	1	0	0	0

Enc_pos: The hexadecimal value of 21-bit absolute encoder position.

ADrive SW: V8.30
Encabit SW: V1.03

SOFTWARE VERSION SCREEN

The software version of ADrive inverter and ENCABIT-Plus module.

B.Resistor : % 4
**.....

BRAKING RESISTOR USING SCREEN

The using rate of braking resistor during braking.

17. ADrive Parameters

The parameters of the inverter can be adjusted by using the buttons and the LCD on the device or by a PC or Laptop on which ADrive-Win software is installed. Parameters are grouped according to their functions. The parameters and functions according to groups are explained below.

1-TRAVEL CURVE

2-MOTOR SETUP

3-CONTROLLER SETUP

4-KEY READ/WRITE

5-FAULT HISTORY

6-CONTROL TYPE

7-LANGUAGE

8-FACTORY DEFAULT

9-AUTO TUNE

10-PASSWORD

11-ADVANCED SET

12-BATTERY OPERATION

1-TRAVEL CURVE

- 1.1-HIGH SPEED
- 1.2-MIDDLE SPEED
- 1.3-INSPECTION SPEED
- 1.4-LOW SPEED
- 1.5-ACCELERATION
- 1.6-ACCELERATION BEGIN SOFTEN S1
- 1.7-ACCELERATION END SOFTEN S2
- 1.8-SLOWING DISTANCE
- 1.9-STOPPING DISTANCE
- 1.10-STOPPING TYPE
- 1.11-DECELERATION
- 1.12-DECELERATION BEGIN SOFTEN S3
- 1.13-DECELERATION END SOFTEN S4
- 1.14-MECHANICAL BRAKE ON DELAY
- 1.15-MECHANICAL BRAKE OFF DELAY
- 1.16-INITIALIZING JERK
- 1.17-INITIALIZING SPEED
- 1.18-INITIALIZING TIME

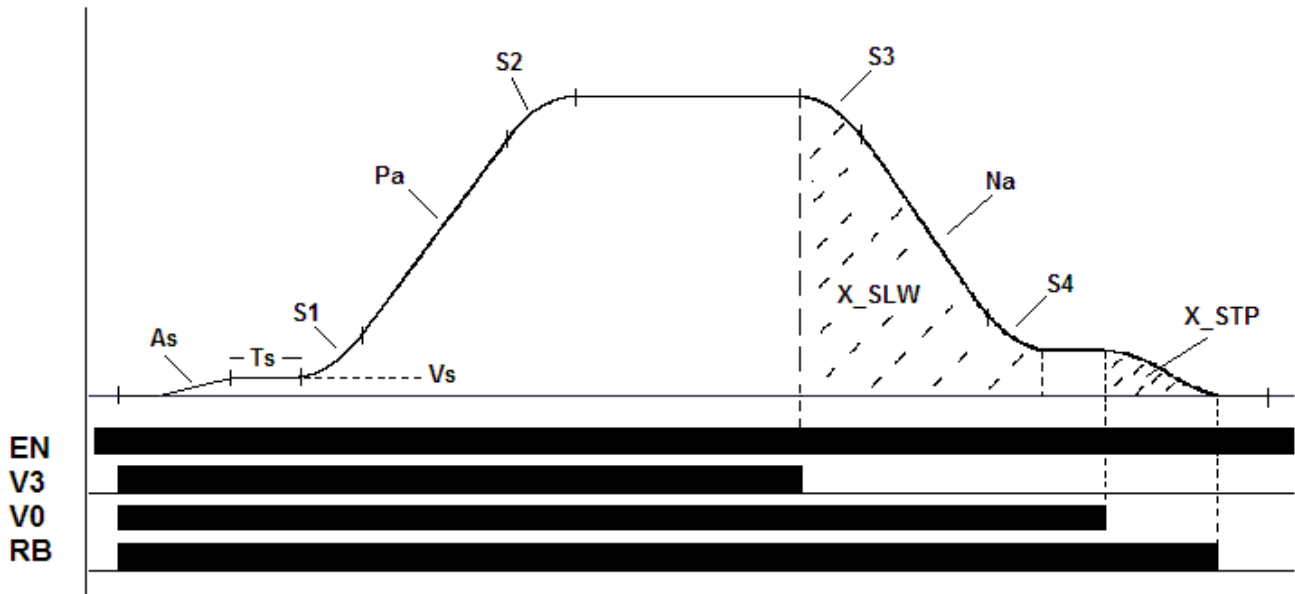

1.2 - 1.4 – High Speed / Middle Speed / Inspection Speed / Low Speed (V3, V2, V1, V0)

The speed which is selected by the V3, V2, V1 and V0 input terminals of the inverter. In a case of more than one speed inputs applied the higher one is activated. If the speed control inputs are driven by relays high speed and low speed signal should be applied together. Otherwise because of the relay delays, wrong speed inputs may be perceived at speed changes especially for distance controlled stops it is important that there must be no delays at speed transitions.

1.5 – Acceleration (PA: 0.10 m/s² – 5.00 m/s²)

The acceleration of the elevator. As the acceleration increases, the speed up time decreases. If decreased the speed up time increases.

1.6-Acceleration Begin Soften (S1: 0.10 – 5 .00 m/s³)

The acceleration of the elevator is not started directly with the parameter PA. By increasing the acceleration smoothly with parameter S1, sharp changes in the acceleration are prevented. Consequently the acceleration is felt less by the passenger.

1.7-Acceleration end soften (S2: 0.10 – 5 .00 m/s³)

At the end of acceleration while passing to constant speed the acceleration is decreased smoothly to prevent sharp changes in the acceleration. Consequently the acceleration is felt less by the passenger.

1.8-Slowing Distance (X_SLW: 10 - 500 cm)

If the STOPPING TYPE at Parameter 1.10 is adjusted to “STP WITH DISTANCE” while the elevator speeds down from V3 to V0, the distance to slow down from V3 to V0 is equalized to the value of this parameter automatically by adjusting the S ramps. No need to adjust the S3-S4 and deceleration parameters.

1.9-Stopping Distance (X_STP: 1 – 50 cm)

If the STOPPING TYPE at Parameter 1.10 is adjusted to “STP WITH DISTANCE” the distance from V0 to 0 speed is equalized to the value of this parameter automatically by adjusting the S ramps. No need to adjust the S3-S4 and deceleration parameters.

1.10-Stopping Type (“Stp with distance” or “With NA/S3/S4”)

Determines that the speed transition from V3 to V0 and from V0 to 0 will be whether according to distance or according to parameters of deceleration.

1.11-Deceleration (NA: 0.10 – 5.00 m/s²)

The deceleration of the elevator. As the deceleration increased, the speed down time decreases. If decreased the speed down time increases.

1.12-Deceleration Begin Soften (S3: 0.10 – 5 .00 m/s³)

The deceleration of the elevator is not started directly with the parameter NA. By increasing the deceleration smoothly with parameter S3, sharp changes in the deceleration are prevented. Consequently the deceleration is felt less by the passenger.

1.13-Deceleration End Soften (S4: 0.10 – 5 .00 m/s³)

At the end of acceleration while passing to constant speed the acceleration is decreased smoothly to prevent sharp changes in the acceleration. Consequently the acceleration is felt less by the passenger.

1.14-Mechanical Brake on Delay (MB_ON: 0.1 – 3.0 Sn)

Delay of the mechanical brake open. For this period motor is hold at zero speed and waits for mechanical brake to free motor. At the end of delay the elevator begins accelerating. Too short delays causes vibration because of torque on the motor before the mechanical brake opens. Too long delays increase the travel time.

1.15-Mechanical Brake off Delay (MB_OFF: 0.1 – 3.0 Sn)

Delay of the mechanical brake close. After the elevator reaches zero speed the motor continue to drive at zero speed for this period. Too short delays causes the motor power cut off before the mechanical brake blocks motor. In this situation the car may move out of control to heavier direction. The elevator controller card must hold the contactors till the end of the this time. If this is not done, the sparks at contactor contacts may disturb the driver.

1.16-Initializing Jerk (As: 0.01 – 4.00 m/s²)

Instead of starting directly with the S ramp, the elevator may be first accelerated to a Vs speed with a As acceleration and to eliminate the rope tension and inertia, the actual ramp is passed over after a delay Ts. This function is suitable for high buildings to eliminate the rope bounce. (Not used if Vs=0)

1.17-Initializing Speed (Vs: 0 – 1.00 m/s)

Please see the parameter 1.16.

1.18-Initializing Time (Ts: 0 – 3.00 Sn)

Please see the parameter 1.16.

2-MOTOR SETUP

- 2.0 – Motor type
- 2.1 – Nominal speed
- 2.2 – Motor RPM at nominal speed
- 2.3 – Incremental encoder resolution
- 2.4 – Line voltage.
- 2.5 – Motor nominal voltage
- 2.6 – Motor nominal current
- 2.7 – Motor nominal frequency
- 2.8 – Motor power factor (COS Q)
- 2.9 – Rotor slip
- 2.10 – No load motor current (%)
- 2.11 – Rotor time constant
- 2.12 – Middle frequency
- 2.13 – Middle frequency voltage
- 2.14 – Minimum frequency
- 2.15 – Minimum frequency voltage
- 2.16 – Thermal mod
- 2.17 – Motor direction
- 2.18 – Encoder direction
- 2.19 – Number of poles
- 2.20 – Encoder offset
- 2.21 – Absolute encoder type



Motor setup affects the driver's performance directly so these values must be adjusted carefully in accordance with the information below.

2.0 – Motor type (Induction / Synchronous)

The type of lift motor. If synchronous motor is selected, **6.1** control type parameter can only be set to closed loop.

2.1-Nominal Speed (VN: 0.10 – 5.00 m/s)

The nominal speed of the elevator machine. This value is given by the machine manufacturer and shown on the machine plate.

The suspension ratio of the elevator system is also determines the nominal speed. By using a 2:1 suspension ratio, the elevator nominal speed will be a half of the motor nominal speed.

Nominal speed may be calculated by this formula:

$$V_{nom} = \frac{2 * \pi * RadiusofTractionSheave * MotorNomRpm}{60 * GearRatio * RopeSuspensionRatio}$$

For example radius of traction sheave = 40cm, Motor nominal rpm = 1430, Gear ratio = 1 / 60 and rope suspension ratio = 1:1

$$V_{nom} = \frac{2 * \pi * 0.4 * 1430}{60 * 60 * 1} = 1m/s$$

2.2-Motor RPM At Nominal Speed (Rpm_Motor: 100 – 5000 rpm)

The motor RPM at which nominal speed is gained.

2.3-Incremental Encoder Resolution (Pulse: 100 – 5000 Pulse/Rev.)

The pulse of the incremental encoder per revolution. This parameter is not used for absolute value encoders.

2.4-Line Voltage (Vline: 300 – 420 Volt)

Line voltage applied to L1, L2, L3 terminals.

2.5 -Motor Nominal Voltage (Vmotor: 100 – 400 Volt)

Voltage that must be applied to motor for full speed. This value is specified on the motor plate by the motor manufacturer. The voltages are different for star and delta connections so don't forget to check the connection type.

2.6-Motor Nominal Current (Imotor)

Nominal current of the motor. This value is specified on the motor plate by the motor manufacturer.

2.7-Motor Nominal Frequency (Fmotor: 10 – 100 Hz)

Nominal frequency of the motor. This value is specified on the motor plate by the motor manufacturer.

2.8-Motor Power Factor (COS Q: 0.1 – 1.0)

Motor power factor. This value is specified on the motor plate by the motor manufacturer.

2.9-Rotor Slip (R_slip: 1.0 – 9.0 Hz)

Asynchronous motors have a slip between rotor and electrical rotating field applied to stator. The value of this slip is entered by this parameter. Too small slip value causes over current and heating of motor. Too high slip causes unstable motor current and vibration. It is advised not to change this parameter's default value if there is no need. Slip frequency may be calculated by the formula below:

$$F_{slip} = \frac{(StatorNomRpm - MotorNomRpm)}{(StatorNomRpm)} * F_{nom}$$

$$StatorNomRpm = \frac{F_{nom} * 60}{(numberofpdes / 2)}$$

For example : The slip for a 50Hz , 1440 rpm , 4 poles motor is like below:

$$StatorNomRpm = \frac{50 * 60}{2} = 1500 \text{ Rpm}$$

$$F_{slip} = \frac{(1500 - 1440)}{(1500)} * 50 = 2 \text{ Hz}$$

2.10-No Load Motor Current (Inoload: %20 - %80)

Ratio of no load current to nominal current. Too high value causes high motor current. Consequently motor heat rises and more power consumed. Too low value causes torque loss which shows itself as a vibration. Values of parameters 2.9 and 2.10 are very critical values for the motor drive performance. Optimum value is where minimum motor current is obtained without vibration. For getting to this optimum values the elevator must run a few times and the motor current should be monitored.

2.11-Rotor Time Constant (T_rotor: 1- 999 ms)

Time constant for motor rotor. Dependence of the inverter to this parameter is reduced, do not change this parameter if not necessary. This value may be get from the motor manufacturer. This parameter is needed for vector control.

2.12-2.15 Motor V/F Table Values (Fmiddle, Vmiddle, Fmin, Vmin)

In open loop mode the inverter applies output voltage vs. output frequency according to this table.

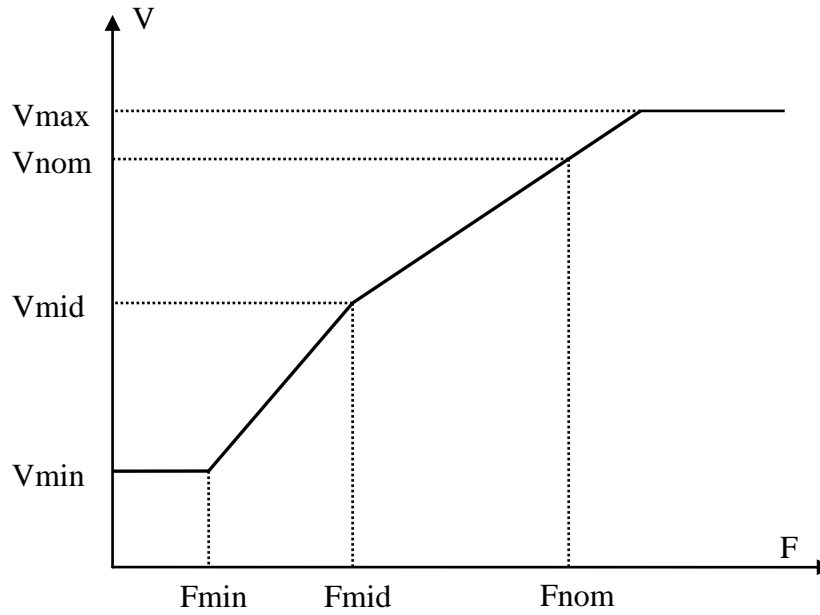

Motor V/F Chart

2.16 - Thermal Mod (Motor_Ther: %20 - %250)

Motor temperature is estimated by a heat model which is formed by the motor parameters. Heat model determines the temperature of the motor by using the current and rpm of the motor. Default value for this parameter is %100. Higher values allow more load up on motor while less values increases thermal protection sensitivity.

2.17 – Motor Direction (Not inverted / inverted)

This parameter can be used to change the motor direction. If motor goes in the wrong direction, the wires to the motor must be reversed. Motor's direction can also be reversed easily by using this parameter without making any wiring changes.

2.18 – Encoder Direction (Not inverted / inverted)

This parameter can be used to change the encoder direction. If driver gives wrong direction error after the correct wiring of encoder in a closed-loop control, the connection of encoder phases must be reversed. Encoder's direction can also be reversed easily by using this parameter without making any wiring changes.

2.19 – Number of poles (M_Poles: 2, 4, 6, ... , 64)

The number of poles of the motor. Enter the data on the motor name plate.

Note: This value is not the number of pole pairs.

2.20 – Encoder offset (M_Offset: 0.0' - 359.9')

The encoder offset angle between the zero point of absolute encoder and the electrical zero point of motor winding for synchronous motors.

Before a normal operation of synchronous motor it is required to measure the encoder offset. This parameter is measured automatically by the inverter during auto tune. For further information see section “20. Driving Synchronous Machines with ADrive”

After the auto tune process, note the value of this parameter. When the inverter need to be changed because of a failure, this parameter must be set to this value manually for the new inverter without performing a new auto tune process. The auto tune process must be performed when the relative position between motor and encoder changes.

2.21 – Absolute encoder type (SC.EnDat-2048 / SC.SSI-2048 / SC.SC-2048)

The type of absolute value encoder.

SC.EnDat-2048: 2048 pulse/revolution EnDat encoder.

SC.SSI-2048: 2048 pulse/revolution SSI encoder

SC.SC-2048: 2048 pulse/revolution SinCos encoder

In this version of ADrive only 2048 pulse/revolution value can ve selected. Please ask ARKEL for different pulse/revolution values.

3-CONTROLLER SETUP

- 3.1 – PI speed controller KP0 gain
- 3.2 – PI speed controller KI0 gain
- 3.3 – PI speed controller KP1 gain
- 3.4 – PI speed controller KI1 gain
- 3.5 – Anti-Rollback position controller
- 3.6 – Anti-Rollback position controller Kp gain
- 3.7 – Anti-Rollback position controller Kd gain
- 3.9 – Encoder filter
- 3.10 – Dynamic filter

3.1-3.4 The speed controller Kp and Ki gains (KP0, KI0, KP1, KI1)

PI speed controller integral and proportional factor is adjusted automatically in accordance with travel speed. At zero speed PI speed controller process with KI0 integral factor and it is increased to KI1 at full speed step by step.

At startup of elevator, KI0 and KP0 is hold high to make the PI speed controller's reaction faster to very little speed changes. At full speed there is no need for so much sensitive PI controller because it causes high motor enforce. (For example at startup the reaction must be quick to 5-10 revolution changes, while at 1400 rpm it is meaningless to give sudden torque changes for 5-10 revolutions.)

The integral factor multiplies the total of errors so must be adjusted to very smaller than KP otherwise it causes vibration and overshoots at travel curve. Usually it is better to adjust KP higher than 10xKI.

If KI and KP are too high it makes noise at motor. Too low values cause delays to catch the reference speed and sensitivity loss.

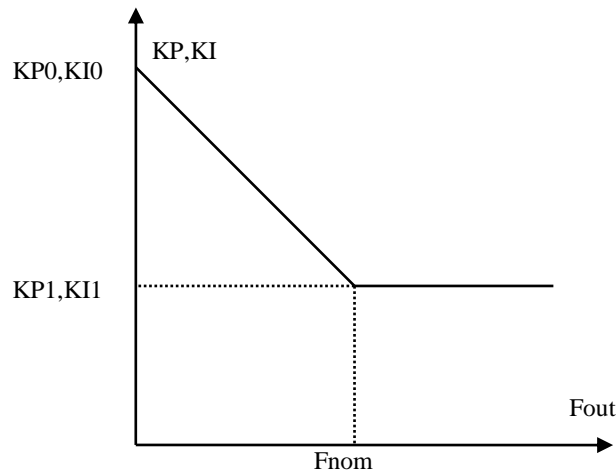
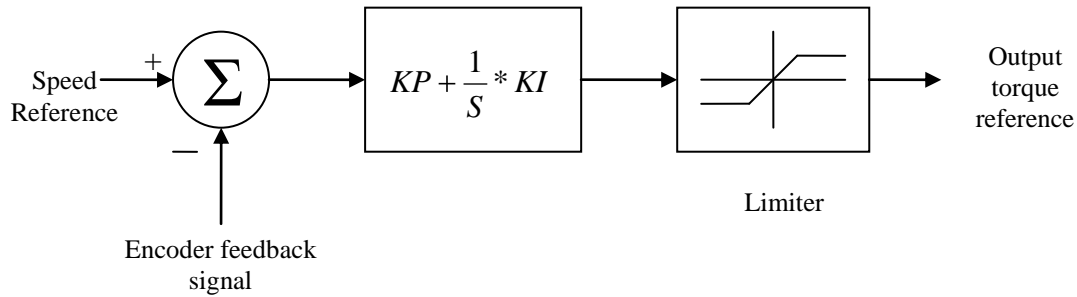

3.5 – Anti-Rollback position controller (Disabled / Enabled)

This function is used only for closed loop applications.

After the mechanical brake is released a rollback may occur because the motor has not yet developed enough torque to hold the car. The car may move up or down depending on the load balance. This effect is most noticeable with gearless motors because of a low friction. The anti-rollback function is used to help prevent rollback on elevators.

Mechanical brake release point is considered as reference point. Unwanted movements to the left or right side from this point will be stopped by applying force to contrary direction with position controller.

Anti-rollback position controller gains are determined by the parameters 3.6 and 3.7. Increasing the gains will cause more quick response to rollback. Reducing the gains will cause late response. Too high gain values can lead noisy and instable startup. Too low gain values cause an appreciable rollback in car. See section “19.4 Improving start-ups” for appropriate Anti-Rollback settings.

3.6- Anti-Rollback position controller Kp gain (KP_ARB: 10 – 2000)

The Kp gain of Anti-rollback position controller.

3.7- Anti-Rollback position controller Kd gain (KD_ARB: 10 – 2000)

The Kd gain of Anti-rollback position controller.

3.9- Encoder filter (Enc_Filter: 1-4)

The filter applied to the encoder value.

- 1: 2 ms
- 2: 4 ms
- 3: 8 ms
- 4: 16 ms

It is recommended to set this parameter to 2 for closed-loop asynchronous motors and to 2 or 3 for synchronous motors.

3.10- Dynamic filter (Disabled / Enabled)

In synchronous motors, as the rom of the motor is low, it may be necessary to use an encoder filter level of 3 or 4. Increasing the filtering level allows a more precise reading of speed but on the other hand delays the reading speed. Selecting dynamic filtering will allow compensation of these delays.

4-KEY READ/WRITE

All parameter of ADrive can be saved to data key and read out from key.

4.1-KEY READ

Parameters in the data key are transferred to inverter.

4.2-KEY WRITE

Parameters of the inverter are transferred to data key

5-FAULT HISTORY

ADrive saves last 256 errors in its memory. By this, facility for maintenance and repairing is provided.

5.1-Watch Fault List

The list of the faults is displayed on the screen. Last error is number 1 and the oldest error is number 256.

5.2-Clear Fault List

All faults in the memory are erased.

6-CONTROL TYPE

Determines that if the control of the motor will be in OPEN LOOP (without encoder) mode or in CLOSED LOOP (with encoder).

6.1 – Control Type (CT: OPEN LOOP / CLOSED LOOP)

When synchronous motor is selected in the menu, this parameter can be adjusted only as a closed loop.

7-LANGUAGE

Selection of the language is made by this parameter.

7.1 – Language (ENGLISH / TURKCE / FRANCAIS)

8-FACTORY DEFAULT

All parameters of the inverter may be changed to factory defaults. For this select YES to question “**Are you sure to set defaults?**” and approve with **ENTER** button.

9-AUTO TUNE

9.1 – Auto Tune (ENABLE / DISABLE / ENABLE_STATIC)

a) Auto tune for Asynchronous motors

Enable auto tune function after entering the motor parameters from the motor plate to determine the V/F values automatically. Device will tune with first command and sets the V/F table.

Detail description is given in the section “18. How to adjust for open loop practically”.

b) Auto tune for Synchronous motors

Before a normal operation of synchronous motors it is required to carry out an auto tune process.

In synchronous motors, auto-tuning may be done while moving the motor (dynamic) or without moving the motor (static).

For dynamic auto-tuning, this parameter must be set to “ENABLE”. Dynamic auto-tuning may only be performed when the motor is free from any load or when the car and counter-weight are in exact balance. During auto-tuning, the motor will turn 1 revolution clockwise and 1 revolution counter-clockwise.

For static auto-tuning, this parameter must be set to “ENABLE_STATIC”. Static auto-tuning is performed while the mechanical brakes are locked and the motor is under load. Therefore, the motor will not move during static auto-tuning.

Note: “ENABLE_STATIC” option in the auto-tuning parameter is visible only if “2.21-ENCODER TYP” parameter is set to SC.EnDat-2048, SC.SSI-2048 or SC.SC-2048.

Detail description is given in the section “20. Driving Synchronous Machines with ADrive”.

10-PASSWORD

The ADrive Inverter’s menu is password protected to prevent unauthorised manipulation of control parameters. User password has 4 digits. The default setting for the password is “0000”. It is highly recommended to change it to an individual one having entered lift parameters first.

10.1 – PASSWORD (0000)

11-ADVANCED SET.

- 11.1 – Switching frequency
- 11.2 – The current controller KI gain
- 11.3 – The current controller KP gain
- 11.4 – PIN programmable input function
- 11.5 – Flim Frequency
- 11.6 – Brake release monitoring
- 11.7 – PTC temperature monitoring
- 11.8 – Over-gain detection function
- 11.10 – Trip I_{max}
- 11.11 – Trip I_{maxT}
- 11.12 – Travel current gain

11.1 – Switching frequency (fsw: 7.5 KHz / 10KHz)

The switching frequency of ADrive Inverter. Default setting is 10KHz.

In sites where the motor keeps running frequently, the switching frequency parameter may be set to 7.5 kHz in order to prevent the motor from heating up. Be aware that this setting will increase the audible noise from the motor.

The parameters **11.1**, **11.2** and **11.3** are the advanced parameters of ADrive Inverter. Do not make any changes if not necessary!

11.2 – The current controller KI gain (KI-cur: 10 – 1000)

The current controller KI gain. Default setting is 75.

11.3 – The current controller KP gain (KP-cur: 1000 – 30000)

The current controller KP gain. Default setting is 4000.

11.4 – PIN programmable input function (PIN Func: “Error Reset” / “Shaft Limit Cnt.”)

This parameter determines the function of PIN programmable digital input on ADrive.

Error reset: The device error will be cleared by activating this input.

Shaft limit control: When the input goes from 0 to 1, if the driver output frequency > the limit value set in the parameter **11.5** driver gives an error and stops. This function performs an extra protection with an upper and lower limit switches placed on the car in order to make sure that the elevator is slowed during approaching to shaft limits.

11.5 – Flim Frequency (Flim: 1 – 100)

The limit value of driver output frequency when the parameter **11.4** is set to shaft limit control.

11.6 – Brake release monitoring (Brake mon: Enabled / Disabled)

The control of brake release monitoring function for synchronous motors.

The brake release monitoring micro-switches are connected to P11 input on ENCABIT-Plus module. In order to enable this function, the driver must be equipped with ENCABIT-Plus module and the connection must be made as described in the section **11.2.5**.

11.7 – PTC temperature monitoring (PTC check: Enabled / Disabled)

The control of PTC temperature monitoring function.

Motor PTC & brake resistor thermostat can be connected to PI2 input on ENCABIT-Plus module (usually when the inverter and the lift controller are located in separate places). In order to enable this function, the driver must be equipped with ENCABIT-Plus module and the connection must be made as described in the section **11.2.6**.

11.8 – Over-gain detection function (S_OGD Func: Enabled / Disabled)

The control of anti-rollback over gain detection function.

This function can only be enabled when the parameter **3.5** Anti-rollback position controller is activated.

If too high values are entered for anti-rollback position controller gains **3.6** and **3.7**, the motor can go into oscillation at startup. This case can lead noisy and instable startup. This function is used to detect the over-gain. When an over-gain is detected, the inverter gives the following warning:

H.TORQUE RIPLE
CHECK ARB GAINS

Then the inverter stops the OGD function and drives the motor with acceleration ramp.

It is suggested to keep this function enabled.

11.10 – Trip I_{max} (Err_I_{max}: 4 - 99 A), **11.11-Trip I_{maxT}** (Err_I_{maxT}: 0.1 – 9.9 s)

These parameters are used to limit the motor current. ADrive will give the “I_{max_Trip limit” error when the motor current exceeds the value set in parameter **11.10** during the period of time set in parameter **11.11**.}

The device’s current limit may be harmful for the motor when the capacity of device is larger than the motor capacity. In such cases, it will be appropriate to limit the motor current with these parameters.

11.12 – Travel current gain (% 10 - % 100)

At the instant where the mechanical brake is released, the force caused by the imbalance of the car and counter-weight is transferred instantaneously by the ropes to the rotor. At this instant, the driver has to increase the motor current immediately to enable the rotor to stand-still without rolling back. That’s why, PI controller gains for the motor current (11.2. KI_{cur} and 11.3.KP_{cur}) are desired to be as high as possible during startup. But adversely, keeping these gains high during travel will cause fluctuations in motor current and will cause vibrations and humming noises. This parameter allows reducing the gains during travel. For example, if this parameter is set to 25%, the gains during travel will be 1/4th of the gains used during startup.

11.13 – Current limit (I_lim)

It is used to set the current limit. It is set to 2 x motor current during the auto-tuning process. The limit value is the maximum current of the inverter. This values are shown below.

A Drive (HP)	Current Limit (A)
7.5	28,2
10	35.3
15	53
20	70A
30	101.1
50	140

12-BATTERY OPERATION

12.1 – Battery voltage (BAT_Volt: 60-120V, 220V UPS)

This is the setting of the back-up power which will be used during evacuation. Either a 60-120V battery pack or a suitably rated 1-phase 220VAC UPS may be used.

12.2 – Battery direction (BD: EASIEST DIR / COMMAND DIR)

The type of direction during evacuation operation.

Easiest direction: The evacuation direction is determined by the inverter. ADrive ignores the applied speed and direction commands and starts running the motor in the in the lower load direction with a maximum allowed speed limited with the parameter **12.3**.

Command direction: The evacuation direction is determined by the lift control system. Inverter ignores only the applied speed command and starts running the motor in the direction applied to input terminals UP/DWN with a maximum allowed speed limited with the parameter **12.3**.

12.3 – Battery speed (V4: 0.05 – 5.00 m/s)

Maximum evacuation speed allowed during evacuation operation.

The maximum speed that can be achieved during evacuation operation depends on the type of motor and loading of the car (evacuation in the lower-load evacuation or command direction). Max. allowed evacuation speed is limited to the value of this parameter. Even if the elevator system allows higher speeds, the car speed will not exceed this value.

12.4 – UPS power (UPS_pw: 0.5 – 20 kW)

This parameter is for protecting the UPS device. It will be visible if “12.1-BAT.VOLTAGE” parameter is set to “220V UPS”. This is the maximum power which can be drawn from the UPS during evacuation. The driver prevents the UPS from overloading by limiting its power to this value.

First of all, the power rating of the UPS must be calculated in kW. Making of those calculations are explained on section 13.3.3.1 (for lower-load evacuation) and section 13.3.4.1. (for command direction evacuation).

18. HOW TO ADJUST FOR OPEN LOOP PRACTICALLY

To run the device in open loop mode (without encoder) apply the below step by step.

- Read the motor plate and enter these values to the inverter using MOTOR SETUP menu.
- ENABLE AUTO TUNE function and run the elevator in inspection mode. Keep giving movement command until AUTO TUNE END message is displayed on the inverter display. The motor current must be entered correctly before auto-tune. (Too high current will cause over current and heating of motor. Too low current will cause torque loss at low speeds and stopping sensitivity will decrease).
- Move the elevator in inspection mode and be sure that it is going in the right direction. If the main controllers' direction is reverse of the elevators direction change the order by the parameter **2.17-Motor direction**.
- Run the elevator with V0 speed and check the motor current if it is higher than nominal motor current decrease Middle Voltage at V/F table. Ideal balanced current is %75 of motor current.
- Be sure that nominal speed (parameter **2.1-Nominal Speed**) of the elevator and rpm (parameter **2.2-Motor RPM At Nominal Speed**) of the motor are correctly entered.(For example for 0,6 m/sn elevator nominal speed = 0,6 m/sn – nominal rpm = 830 or for 1 m/sn elevator nominal speed = 1 m/sn – nominal rpm = 1430). Don't change these parameters to speed up or slow down the elevator. These parameters are only machine information.
- Enter the speed references at TRAVEL CURVE menu. For applications to speed up the elevator over the nominal speed, adjust the high speed maximum %30 over the nominal speed. (For example nominal speed 0,6m/sn – maximum high speed 0,8 m/sn or nominal speed 1 m/sn – maximum high speed 1,3 m/sn). **Be sure that mechanical safety is suitable for this new higher speed (Mechanical brakes, safety gears, rails, shaft etc.).**
- Enter the slowing distance. Adjust this parameter to a value 10-20 cm less than the distance of the slowing magnets to floor to achieve a secure distance for elevator to slow down and approach to floor at low speed.(For example if the magnet distance is 170cm, enter the slowing distance 155 cm). If the elevator slows down early and then travels at low speed too much, increase slowing distance parameter. On the contrary if the elevator is late to slow down and passes the floor level decrease the slowing distance parameter.
- Enter the stopping magnets distance from exact floor level to stopping distance parameter (Ex. 7cm). This distance must be neither too much nor too little. For example a value of 1cm is not a realistic value. Because the stoppings will be unstable since it is out of motor power limits to stop an elevator which goes at low speed in 1 cm. For a long distance like 30 cm the stopping accuracy will be missed with full and empty car.

Example:

Imot:	16.0 A	V3: 1.0 m/s	X_Slw: 165 Cm
Vmot:	380 Volt	V0: 0.13 m/s	X_Stp: 8 Cm
Rpm_nom:	1450		

19. HOW TO ADJUST FOR CLOSED LOOP PRACTICALLY

To run the device in closed loop mode (with encoder) apply the below step by step.

- First make the adjustments for open loop and be sure that the elevator is running in open loop mode.
- Connect the encoder and enter the encoder resolution to parameter **2.3-Encoder Resolution**.
- Move the elevator in inspection mode and monitor the motor current. If the current is too high probably the encoder direction is wrong. Change the order by the parameter **2.18-Encoder direction**.
- Rotor slip frequency must be entered correctly to the inverter. Motor slips are high for old motors while small for new motors. (Look parameter **2.9-Rotor Slip** for calculating the motor slip)

Try the slip values from 0.7Hz to 3.0Hz with 0.3Hz steps and make a test run with same way & same load. The appropriate slip value is the one which your motor current is lowest.

Note: If the motor does not reach the estimated rpm, it means that the motor slip is low. If motor current is not stable and there is a high oscillation, it means that the motor slip is high.

- If you cannot solve the vibration problem. To find the source of problem set KI1, KI0 integral values of speed controller to minimum and run again.

If vibration is no longer exists this shows that speed controller needs adjustment not motor parameter. May be integral values are too high or KP difference factors are too small. Run elevator few times to find best values.

If vibration is still exist when KI0, KI1 is min. This means that problem is at motor parameters. Try higher no load currents (2.10) and smaller slips (2.9). When vibration problem is solved set the KI0, KI1 to normal values.

- If necessary change the PI speed controller gains in the **CONTROLLER SETUP** menu.

20. DRIVING SYNCHRONOUS MACHINES with ADrive

20.1. Encoder connection

To be able to communicate with absolute encoders which have to be used with synchronous motors, an additional ENCABIT-Plus communication board is necessary. The encoder wirings to this board must be done as explained in Section 12.2.4.

20.2. Motor parameters

The following values must be entered in the ADrive parameters menu:

2.0-Motor Type: Synchronous

2.1-Nominal Speed: Nominal speed of the car (for example: if the motor speed is 2 m/s and the gear ratio is $\frac{1}{2}$, the value of 1 m/s must be entered)

2.2-Nominal Speed RPM: RPM value indicated on the motor name plate

2.5-Motor Voltage: Motor voltage

2.6-Motor Current: Motor current

2.19- Number of poles: Number of motor poles

20.3. Auto tuning:

a) If possible, a dynamic auto tuning should be performed before hoisting the car (without load). If this is not possible during dynamic auto tuning, an amount of weight which will balance the total car weight and the counterweight should be added into the car. The balance of the counterweight and the car may be checked by manually releasing the brakes and making sure that the car does not move with released brakes.

During dynamic auto tuning, the motor will turn one revolution in each direction. So please make sure that the car has enough distance to the top and bottom of the shaft before starting the auto tuning.

In cases where dynamic auto-tuning is not possible, auto-tuning may be performed statically. For static auto-tuning, "9.1-AUTO TUNE" parameter must be set to "ENABLE_STATIC".

The most precise way to determine the motor offset angle is to perform a dynamic auto-tuning with ropes disconnected from the rotor (without load). With static auto-tuning, an error of up to +/- 12 degrees may be introduced and this error will cause the travel currents to be %3-%4 higher than ideal.

b) To start auto tuning, set the "9.1-Auto tune" parameter to "Enabled" and exit the menu. ADrive will display "Waits Auto tune" on its screen. At this point, turn the switch on the recall terminal to "Rev" position and press either up or down button. Keep the button pressed until you see the message "Auto tune End" on the ADrive screen.

If the message "Wrong direction" is displayed, either toggle the parameter "2.18-Encoder direction" or swap any two of the 3 motor power lines (U, V, W).

If the message "Auto tune fails" is displayed during auto tuning, please check the motor and encoder connections.

c) The auto tuning procedure will determine the correct "2.20- Offset angle", "11.2- Current Controller KI Gain" and "11.3-Current Controller KP Gain" values. It is wise

to note these values and store them in a safe place for future reference. So that you will be able to enter these values manually (without auto tuning) in case of a driver replacement. Remember that the auto tune process must be performed when the relative position between motor and encoder changes.

d) After auto tuning, if the car moves in wrong direction, please toggle the “**2.17- Motor direction**” parameter.

20.4. Improving start-ups

In gearless synchronous machines, the car tends to slip rapidly towards the heavy direction at the moment the brakes are released. For this reason, a special “**Anti-rollback function**” is implemented in ADrive. This function must be tuned carefully in order to minimize the undesired startup trembling. A practical procedure to tune this function is as follows:

- a) Set the “**1.14-Mechanical Brake On Delay**” parameter to 2.0 seconds. This will ensure that the elevator will be held at rest during 2 seconds after brake release.
- b) Unload and position the car to the topmost 1 or 2 meters in the shaft. This is the situation with the worst case of weight balance.
- c) Set the “**3.5- Anti Roll Back**” parameter to “Enabled”.
- d) Set the “**3.6- KP_ARB**” parameter to 60
Set the “**3.7- KD_ARB**” parameter to 20

Press the down button in the recall terminal. The car will slip upwards a little and will stop. After the end of “Mechanical brake opening time” (which we had set to 2 seconds”, the car will start to move downwards with inspection speed. Increase the “**3.6**” and “**3.7**” parameters slightly and retry moving the car in recall mode. Observe the amount of slip in each retry until you find the values where the slip is not noticeable.

In general, the value of “**3.7**” should be about 1/3rd of the value of “**3.6**”. For example, if you set “**3.6**” to 120 then 40 will be a reasonable value for “**3.6**”.

When these parameters are given too high, the motor will make loud noises and will start to shake on startup. This kind of startup is harmful for the driver and the motor. Also is very undesirable in terms of passenger comfort. So it is advised to find the critical values which lead to this undesired startup and to make sure **NOT** to set the values to **greater than the half** of these critical values.

- e) Change the “**1.14-Mechanical Brake on Delay**” parameter to 1.0 seconds again. If this parameter is given too long, the car will waste time unnecessarily. If it is too short, the motor will try to move before the brakes are fully released and this will be felt in the car as a harsh startup.

20.5. Improving travel comfort

Travel comfort depends on 2 main factors:

1. Shape of the reference speed curve
2. Ability to follow the reference speed curve reliably without vibrations

To achieve a good travel comfort, initially a smooth driving without vibrations should be ensured and then the reference speed curve must be adjusted to give the desired travel.

ADrive uses a PI (proportional-integral) controller to drive the motor trying to follow a reference speed curve. At any given time, the PI controller needs two gain coefficients (KP and KI) to calculate the voltage and frequency to be supplied to the motor. The limit values for these coefficients should be entered to ADrive in the “**3-Controller setup**” menu:

“**3.1-KP zero speed**”

“**3.2-KI zero speed**”

“**3.3-KP full speed**”

“**3.4-KI full speed**”

These zero speed and full speed values are the limit values for the KI and KP gain coefficients. The actual gain coefficient to be used at any moment is calculated instantaneously by interpolating these limits by the current speed of the motor.

To adjust these limit values, the following practical procedure may be applied:

a) Initially set these values:

“**3.1-KP0**” and “**3.3-KP1**” to 500

“**3.2-KI0**” and “**3.4-KI1**” to 10

“**3.9-Encoder filter**” to 2

b) By pressing the up button on ADrive keyboard, find the **RPM Error Screen**. Give a command to the elevator and observe the rpm error while the car is accelerating and decelerating. If the rpm error goes beyond 5%, increase the KI and KP gain coefficients. As the gain coefficients are increased, the controller will respond more quickly to the difference between the reference and actual speed values. But if the coefficients are increased too much, the actual speed will start to oscillate around the reference speed, noise and vibrations will be felt on the motor.

In practice, it is suitable to use 1/60th to 1/30th of KP values as the KI values. If the controller behaves differently between slow and high speeds, it is possible to use separate values or zero speed and high speed.

Warning:

While travelling in inspection or recall modes, if you release the pressed (up or down) button, the safety circuit will be cut-off and the contactors will drop suddenly. This will cause the car to stop immediately and sometimes will cause the driver to give “Motor current too high” or “IPM error” trips. This behavior is normal. When immediate stopping is not needed, you can make the car stop smoothly. To do this, instead of releasing the pressed button, press the other button (up or down) too. When both buttons are pressed, the car will slow down and come to a stop. After the car has fully stopped, you can release both buttons.

21. TRIPS

No	Trip	Meaning	Probable Causes / Corrective Actions
01	IPM ERROR	A fault signal is detected from Inverter's IPM power transistors block.	<p>1- A short-circuit or ground fault occurred at the U, V, W motor output. Check motor connection.</p> <p>2- The IPM temperature may be too high because of the Inverter's cooling fan has stopped. Check cooling fan.</p> <p>3- An over-current may be occurred on the output of inverter so that inverter may have overheated because of the incorrect parameter setting. Check the parameter setting.</p> <p>4- The main supply voltage may be too low. Check the L1, L2, L3 voltages.</p> <p>5- The main contactors of motor output have not to change its position while the inverter driving the motor. If the contactors drop after the inverter stops driving and waits as the brake delay time, increase the contactor delay time. Check the contactor's supply voltage if the contactor changes its position while the inverter driving the motor.</p>
02	LOW DC BUS	<p>The DC Bus voltage is below the under voltage detection level.</p> <p>If mains power is active: $V_{bus} < 400 \text{ V}$</p> <p>If battery power is active: $V_{bus} < (V_{bat} \times \%70)$</p> <p>If UPS power is active: $V_{bus} < 200\text{V}$</p>	<p>1- If mains power is active: The main supply voltage may be too low. Check the L1, L2, L3 voltages.</p> <p>2- If battery power is active: Check the battery voltage on the terminals L1 and L3.</p>
03	HIGH DC BUS	<p>The DC Bus voltage exceeded the overvoltage detection level.</p> <p>If mains power is active: $V_{bus} > 715 \text{ V}$</p> <p>If UPS power is active: $V_{bus} > 420\text{V}$</p>	<p>1- Braking resistor may not be connected properly. Check broken or disconnected wiring.</p> <p>2- Braking resistor's resistance may be incorrect. Be sure that the braking resistor is suitable for Inverter's power and motor power.</p>

No	Trip	Meaning	Probable Causes / Corrective Actions
04	OVER CURRENT	The inverter output current exceeded the over current detection level.	1- Because of the acceleration time of the elevator is too short motor current may increase. Decrease the acceleration parameter PA. 2- Check the V/f characteristics. Decrease Vmid (Middle frequency voltage) and Vmin (Minimum frequency voltage). 3- The motor being used has a capacity more than Inverter's maximum motor capacity. Check the Inverter's motor power.
05	PAR.DATA CORRUPT	The parameters of the inverter are erased or corrupted.	1- Change the parameters of the inverter to factory defaults. Then reenter your configuration.
06	MOTOR OVER LOAD	The motor overload protection function has operated based on the internal electronic thermal value.	1- Check the motor rated current. 2- Check the "Motor Setup - Thermal Mod" parameter. The parameter may be too low.
07	POWER FAILURE	The main supply voltage L1, L2, L3 oscillates unusually.	1- The main supply voltage is too low. 2- An open-phase error occurred at the input power supply. 3- A momentary power loss occurred. 4- The wiring terminals for the input power supply are loose. 5- The voltage fluctuations in the input power supply are too large.
08	AUTO TUNE FAILS	A fault occurred during auto tuning in open loop mode. Auto tune operation cannot be completed.	1- Check motor connection. Motor connection may not be done properly. 2- Motor contactor may not be switching. Be sure that the motor contactor closes when inverter is running.
09	OVER SPEED	The speed read from encoder is too high.	1- Motor speed may be higher than the reference speed. Check motor setup in the menu. 2- Compare the pulse number setting in the menu "Motor Setup - Encoder Resolution" with the encoder pulses and correct if necessary.
10	BAD ENCODER SGNL	The encoder signals oscillate unusually.	1- Check encoder connection and encoder voltage. 2- Check the connection between encoder and motor. 3- If the encoder cable is not shielded, use a shielded cable. 4- If the motor cable is not shielded, use a shielded cable. 5- Encoder cable may be placed too close to motor cable. Motor cable and encoder cable channels should be separate. Minimum distance between cables should be at least 10cm. 6- Encoder may be grounded at both the motor side and inverter side. If the encoder is grounded at motor side, disconnect the grounding at inverter side.

No	Trip	Meaning	Probable Causes / Corrective Actions
12	CONTACTOR DROPPED	The main contactor(s) dropped out while driver is running.	Check the supply circuit of the main contactors' coils.
13	NO CONTACTOR SGN	No contactor picked up signal is detected in 5 seconds after a speed signal and direction signal are detected.	Check the auxiliary contacts of the main contactors in drive enable (EN) signal circuit.
14	LOW MOT. CURRENT	No current can be delivered to motor coils.	1- Motor wiring may not be connected properly. Check broken or disconnected wiring. 2- Check the connection of main contactors.
15	WRONG DIRECTION	Lift is not running in required direction. Running direction read from encoder is different from the direction inverter commands.	1- U, V, W phases of motor reversed. Check motor connection. 2- Phase of encoder reversed.
16	UNBALANCED CUR.	Unbalanced current at U, V, W motor outputs. Over-current at one or two of motor outputs.	1- Contacts of main contactor may not conduct. Check the connection of main contactors. 2- A faulty motor windings.
17	UP/DOWN TOGETHER	The up and down direction signals are activated at the same time.	Check the connection of direction signals of ADrive and controller. UP terminal must be used for up direction signal and DWN terminal must be used for down direction signal.
18	PAR_2.2 IS WRONG	Parameter 2.2. motor rpm at nominal speed may be too low or too high.	For synchronous motors, parameter 2.2 should be ≤ 400 . For asynchronous motors, parameter 2.2 should be ≥ 400 .
19	LOW SPEED	Motor cannot reach to the desired speed.	1- Make sure that the mechanical brakes are released. 2- Check encoder connection 3- In induction motors, rotor-slip may be entered too low. Check this value. 4- In synchronous motors, motor offset angle may be wrong or it may be that the auto-tuning was performed while the encoder direction parameter setting was wrong. Reverse the encoder direction setting (2.18) and perform auto-tune again 5- In synchronous motors, number of motor poles may be set incorrectly (2.19)
20	INTERNAL ERROR 2	The reference speed is higher than V3 speed.	1- Ensure that V0, V1 and V2 speeds are not higher than V3. 2- The Acceleration end soften S2 may be too high.

No	Trip	Meaning	Probable Causes / Corrective Actions
21	INTERNAL ERROR 3	An unexpected situation occurred at motor outputs	<p>1- Ensure that the main contactors are not picked up and dropped out during the drive.</p> <p>2- Check the connection of ENABLE signal.</p> <p>3- Check whether there is looseness in motor and contactor connection.</p> <p>4- Ensure that the components such as brake coil, contactor coil that may create electrical noise have appropriate filtering.</p>
22	Fout > Flim	Drive output frequency is higher than the limit value set in parameter 11.5 in an disallowed area (at lower or upper shaft limit)	<p>1- Ensure that the parameter 11.4 PIN input function on ADrive is not assigned to “Shaft limit control” unnecessarily.</p> <p>2- PIN input function is assigned to “Shaft limit control” and shaft lower/upper additional limit switch has interrupted the drive.</p> <p>3- Check that the parameter 11.5 is not set too low.</p>
23	ENCABIT TIME OUT	The communication between ADrive and ENCABIT-Plus module cannot established	<p>1- Ensure that the ENCABIT-Plus module is mounted on ADrive.</p> <p>2- Check the connection between ADrive and ENCABIT-Plus module.</p>
24	ENCODER ERROR	The encoder connection or the encoder data is incorrect	Check the encoder connection.
25	AUTO TUNE ERROR	The auto tune process could not be completed in closed loop mode.	<p>1- Because the motor is not connected the auto tuning may not have been completed.</p> <p>2- Check the encoder connection</p> <p>3- The motor contactors may not pick up. Ensure that the motor contactors are picked up when the inverter starts running.</p> <p>4- Ensure that the auto tuning is performed load at motor shaft or with load balanced for synchronous motors without.</p>
26	BRAKE MON.ERROR	Mechanical brake monitoring error	<p>1- The brake release monitoring function is activated, so check the connection of brake switches made to PI1 input on ENCABIT-Plus module.</p> <p>2- Check the mechanical brake connection and make sure the brakes are opened and closed.</p>

No	Trip	Meaning	Probable Causes / Corrective Actions
27	MOTOR PTC ERROR	Motor PTC temperature monitoring error	1- The motor PTC temperature function is activated, so check the connection of PTC/thermostat circuit made to PI2 input on ENCABIT-Plus module. 2- Motor PTC circuit may be interrupted.
28	Imax TRIP LIMIT	The motor current exceeds the value set in parameter 11.10 during the period of time set in parameter 11.11	1- Ensure that the parameters are correctly set. 2- There may be a mechanical strain in the motor. 3- Check that the mechanical brake is opening and closing correctly.
29	LOW BATTERY	The required power for driving the motor cannot be taken from the battery set.	1- Ensure that the connected battery set has suitable voltage (60V) and capacity (7Ah). 2- The batteries may be discharged. Keep the batteries on charge.
30	RESITOR OVER RUN	The braking resistor has been used very intensively. It is under dangerous overheat conditions.	Braking resistor's resistance may be incorrect. Be sure that the braking resistor is suitable for Inverter's power and motor power.
31	LOW CPU SUPPLY	The CPU supply is low. (Only in ADrive Size-D)	1- The value of 3 phase AC supply may have fallen below 340 V. Check the voltage of the terminals in L1, L2 and L3. 2- If the device is being supplied from an external 24 VDC source, check the voltage of this external source. 3- If the circuit voltages are all normal, unplug the device and contact ARKEL technical support.

23. ADrive PARAMETER LIST

ADrive MENU	USER SETTINGS	FACTORY DEFAULTS											
		Induction						Synchronous					
		5,5 kW	7,5 kW	11kW	15kW	22kW	37kW	5,5 kW	7,5 kW	11kW	15kW	22kW	37kW
TRAVEL CURVE													
1.1	High speed (V3)	1,0 m/s											
1.2	Middle speed (V2)	0,5 m/s											
1.3	Inspection speed (V1)	0,2 m/s											
1.4	Low speed (V0)	0,13 m/s											
1.5	Acceleration (Pa)	0,4 m/s ²											
1.6	Acceleration begin soften (S1)	0,3 m/s ³											
1.7	Acceleration end soften (S2)	0,4 m/s ³											
1.8	Slowing distance (X_SLW)	165 cm											
1.9	Stopping distance (X_STP)	8,0 cm											
1.10	Stopping type	Stop with distance											
1.11	Deceleration (Na)	0,7 m/s ²											
1.12	Deceleration begin soften (S3)	0,8 m/s ³											
1.13	Deceleration end soften (S4)	0,8 m/s ³											
1.14	Mechanical brake on delay (MB_ON)	0,8 s											
1.15	Mechanical brake off delay (MB_OFF)	0,5 s											
1.16	Initializing jerk (As)	0,03 m/s ²											
1.17	Initializing speed (Vs)	0,0 m/s											
1.18	Initializing time (Ts)	0,0 s											
MOTOR SETUP													
2.0	Motor type	Induction						Synchronous					
2.1	Nominal speed	1,0 m/s											
2.2	Motor RPM at nominal speed	60											
2.3	Incremental encoder resolution	1024											
2.4	Line voltage	380 V											
2.5	Motor nominal voltage	380 V											
2.6	Motor nominal current	9,0 A	14,0 A	19,0 A	25,0 A	35,0 A	50,0 A	9,0 A	14,0 A	19,0 A	25,0 A	35,0 A	50,0 A
2.7	Motor nominal frequency	50 Hz											
2.8	Motor power factor (COS Q)	0,8											
2.9	Rotor slip	2,0 Hz	1,7 Hz	1,5 Hz	1,2 Hz	1 Hz	0,7 Hz	-					
2.10	No load motor current (%)	%40											
2.11	Rotor time constant	150 ms	150 ms	250 ms	300 ms	400 ms	500 ms	-					
2.12	Middle frequency	4,0 Hz											
2.13	Middle frequency voltage	40 V											
2.14	Minimum frequency	0,5 Hz											
2.15	Minimum frequency voltage	22 V											
2.16	Thermal mod	%100											
2.17	Motor direction	Not inverted											
2.18	Encoder direction	Not inverted											
2.19	The number of poles	-						16					
2.20	Encoder offset	-						0,0'					
2.21	Absolute encoder type	-						SC-ENDAT 2048					
CONTROLLER SETUP													
3.1	KP0	900											
3.2	KI0	12											
3.3	KP1	750											
3.4	KI1	10											
3.5	Anti-Rollback position controller	Enabled											
3.6	Anti-Rollback position controller Kp gain	60											
3.7	Anti-Rollback position controller Kd gain	30											
3.9	Encoder filter	3											
3.10	Dynamic filter	Enabled											
CONTROL TYPE													
6.1	Control type	Closed loop											
PASSWORD													
10.1	Password	0000											
ADVANCED SETTINGS													
11.1	Switching F	10 Khz											
11.2	Current controller KI gain	75											
11.3	Current controller KP gain	4000											
11.4	PIN programmable input function	Error reset											
11.5	Flim frequency	50 Hz											
11.6	Brake release monitoring	Disabled											
11.7	PTC temperature monitoring	Disabled											
11.8	Over-gain detection function	Enabled											
11.10	Trip I _{max}	20 A	29 A	45 A	65 A	95 A	99 A	20 A	29 A	45 A	65 A	95 A	99 A
11.11	Trip I _{maxT}	5,0 s											
11.12	T_Current gain	%100											
11.13	Cur. Limit	28,2 A	35,3 A	53,0 A	70,0 A	101,1 A	140 A	28,2 A	35,3 A	53,0 A	70,0 A	101,1 A	140 A
BATTERY OPERATION													
12.1	Battery voltage	220-UPS											
12.2	Battery direction	Easiest direction											
12.3	Battery speed	0,1 m/s											
12.4	UPS power	20,0 kW											

AT-UYGUNLUK BEYANI
EC-DECLARATION OF CONFORMITY

Belge no/Tarih : UB3A / 01.05.2012
Document no/Date

İmalatçı firma : Arkel Elektrik Elektronik Tic. Ltd. Şti.
The manufacturer

Ürünün tanımı : ADrive - Asansörler için AC motor sürücü
Product designation : ADrive - AC variable speed driver for elevators

Tanımlanan ürün, aşağıda belirtilmiş olan Avrupa direktifleri ve uyumlandırılmış standartlara uygundur:
The designated product conforms to the provisions of the following European directives and harmonised norms:

Asansör Yönetmeliği 95/16/AT, Uyumlandırılmış Standart TS EN 81-1+A3:2011
Lifts Directive 95/16/EC, Harmonised Norm EN 81-1+A3:2009

A3 uygunluğu sadece, tip-onay sertifikasında belirtilen otomatik denetlenme fonksiyonları için geçerlidir.
A3 conformity is valid only for monitoring functions specified in the type-examination certificate.

Test laboratuvarı : Liftinstituut B.V.Buikslotermeerplein 3811025 XE
Test laboratory : Amsterdam The Netherlands ID No:0400

Sertifika no : NL 12-400-1002-048-10 rev. 1
Certificate no

EMU Direktifi 2004/108/AT ve EMU sertifikasında belirtilmiş olan Uyumlandırılmış Standartlar
EMC Directive 2004/108/EC and the Harmonised Norms listed in the EMC certificate

Test laboratuvarı : Esim Test Hizmetleri San. Tic. A.Ş.
Test laboratory : TOSB Organize San. Böl. 6. Cad. No.1/1
Şekerpınar/Gebze/Kocaeli/Türkiye

Sertifika no : EMC-2010099C
Certificate no

İŞBU BEYAN BELİRTİLEN TALİMATLARA UYGUNLUĞUNU BELGELER, ÖZELLİKLERİ İLE İLGİLİ GARANTİ HAKKI İÇERMEZ. ÜRÜNLE BİRLİKTE VERİLEN TÜM GÜVENLİK UYARILARI, MONTAJ VE İŞLETİM TALİMATLARINA UYULMASI GEREKİR.

THIS DECLARATION CERTIFIES COMPLIANCE WITH THE INDICATED DIRECTIVES BUT DETERMINES NO WARRANTY OF PROPERTIES. ALL SAFETY INSTRUCTIONS ON PRODUCTS DOCUMENTATION AND MOUNTING INSTRUCTIONS ETC. MUST BE OBEYED.

Yetkili imza / *Legally binding signature*
Melih Küçükçalık



Bu sayfa bilerek boş bırakılmıştır.
This page is intentionally left blank.